

SELECTED TECHNICAL ASPECTS OF TU-154M SMOLENSK AIR CRASH ON APRIL 10, 2010

JACEK F. GIERAS

Department of Electrical Engineering, University of Technology and Life Sciences, Bydgoszcz, Poland

ABSTRACT. This is a collection of reports that consists of three parts. The author is a Professor of Power Electrical Engineering, so he focuses on the Tu-154M power electric system and all aspects of the air crash that relate to electrical equipment and wiring.

Part I discusses the electric power system of the Tu-154M. After brief introduction to aircraft electric power systems, the results of reverse design and analysis of GT40PCh6 wound-field synchronous generator including short circuit have been presented. An example of failure of GT40PCh6 generator is the fire of the Tu-154B-2 on January 1, 2011 before taking off at Surgut airport (flight 7K348). Guidelines for proper investigation of aircraft electric equipment and wiring after crash have been given. There is no evidence of examination of most electrical equipment of the Tu-154M No 101 after crash on April 10, 2010. It is now extremely difficult to determine, if the electric power system of the Tu-154M No 101 was operating correctly in the last seconds of the flight, or not.

Part II analyzes the fuel system and possibility of explosion of fuel-air mixture as a result of static electricity and/or arcing in the left wing outer fuel tank of the Tu-154M No 101. Examples of explosions of fuel tanks (Boeing 747-131 TWA 800 on June 17, 1996 and Boeing 727-200 at Bangalore Airport on May 4 2006) have been discussed. Although probability of explosion of fuel-air mixture in the left wing outer tank due to static electricity, electric short circuit or arcing is low, this problem should be carefully considered in future examination of the wreckage and remaining electrical wiring and equipment.

Part III describes a comparative analysis of full-scale dynamic crash test of Douglas DC-7, full-scale dynamic crash test of Lockheed Constellation 1649 and hypothetical collision of the Tu-154M No 101 with birch tree. The analysis pertains to the technical data of the DC-7, LC-1649 and Tu-154M airliners, differences in their construction and conditions of collision/impact.

Keywords: Aircraft, collision, comparative analysis, crash, DC-7, electric equipment, electric power system, explosion, failure, fuel-air mixture, fuel tank, full-scale test, investigation after crash, LC-1649, synchronous generator, Tu-154M, wing, wiring.

BACKGROUND

On April 10, 2010, a Polish Air Force Tupolev Tu-154M, registration number 101 carrying Poland's President Professor Lech Kaczynski, the First Lady Mrs Maria Kaczynska, top Polish Army generals, Polish representatives, and many distinguished Polish persons performing a states flight from Warsaw (Poland) to Smolensk (Russia) crashed onto the ground coming to rest about 500 m short of the runway threshold of Smolensk North (Severnij) Military Air Base (XUBS). All 88 passengers and 8 crew members have been killed. The debris field being about 210 meters long shows unbelievable fragmentation of the aircraft since the speed

of the aircraft was only 260 to 270 km/h and the aircraft hit the boggy and woody ground. The crash investigation has been handed over by Polish authorities to Russia's Interstate Aviation Committee (Miezhgosudarstviennyi Aviatzionniy Komitet – MAK). The wreckage and flight recorders (black boxes) have not been returned to Poland and are still kept in Russia.

Part I discusses electric power system of the Tu-154M. After brief introduction to aircraft electric power systems, the results of reverse design and analysis of GT40PCh6 wound-field synchronous generator including short circuit has been presented. An example of failure of GT40PCh6 generator is the fire of the Tu-154B-2

on January 1, 2011 before taking off at Surgut airport (flight 7K348). Guidelines for proper investigation of aircraft electric equipment and wiring after crash have been given. There is no evidence of examination of most electrical equipment of the Tu-154M No 101 after crash on April 10, 2010. It is now extremely difficult to determine, if the electric power system of the Tu-154M No 101 was operating correctly in the last seconds of the flight, or not.

Part II analyzes the fuel system and possibility of explosion of fuel-air mixture as a result of static electricity and/or arcing in the left wing outer fuel tank of the Tu-154M No 101. Examples of explosions of fuel tanks (Boeing 747-131 TWA 800 on June 17, 1996 and Boeing 727-200 at Bangalore Airport on May 4 2006) have been discussed. Although probability of explosion of fuel-air mixture in the left wing outer tank due the static electricity, electric short circuit or arcing is low, this problem should be carefully considered in future detailed examination of the wreckage and remaining electrical wiring and equipment.

Part III discusses a comparative analysis of full-scale dynamic crash test of Douglas DC-7, full-scale dynamic crash test of Lockheed Constellation 1649 and hypothetical collision of the Tu-154M No 101 with birch tree. The analysis pertains to the technical data of the DC-7, LC-1649 and Tu-154M airliners, differences in their construction and conditions of collision/impact.

Part 1:

EVALUATION, INVESTIGATION TECHNIQUES AND POSSIBILITY OF MALFUNCTION OF ELECTRIC SYSTEM OF TU-154M

1.1 INTRODUCTION TO AIRCRAFT ELECTRIC POWER SYSTEMS

The function of the aircraft electrical system is to generate, regulate and distribute electrical power throughout the aircraft [23, 35]. Aircraft electrical systems and components operate on many different voltages both AC

and DC. Most systems use three-phase, 115/200 V AC, 400 Hz and 28 V DC. There are several different electric generators on large aircraft to be able to handle loads, for redundancy, and for emergency situations, which include (Fig. 1.1) [23, 35]:

- engine driven main generators;
- auxiliary power units (APU);
- ram air turbines (RAT);
- external power, i.e., ground power units (GPU).

Each of the engines on an aircraft drives one or more a.c. generators (Fig. 1.2) via special transmission system.

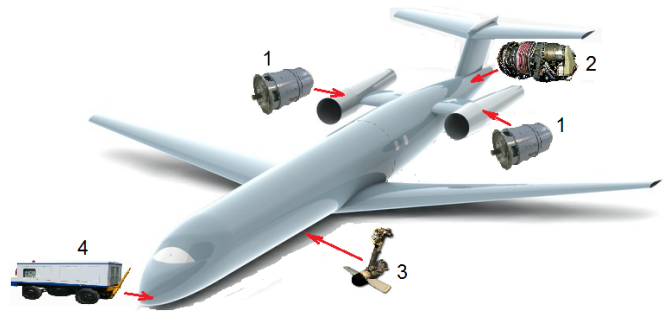

Figure 1.1: Aircraft generators: 1 – main generator, 2 – APU, 3 – RAT, 4 – GPU [23, 35].

The power produced by these generators is used in normal flight to supply the entire aircraft with electric power. The power generated by the APU is used while the aircraft is on the ground during maintenance and for engine starting. Most aircraft can use the APU while in flight as a backup power source. RATs are used in the case of a generator or APU failure, as an emergency power source. External power (GPU) may only be used with the aircraft on the ground. A GPU (portable or stationary unit) provides AC power through an external plug on the nose of the aircraft. Aircraft generators are typically three-phase, salient pole, wound-field rotor synchronous machines with synchronous brushless exciter and permanent magnet (PM) brushless subexciter [23, 35]. The architecture and power circuit is shown in Fig. 1.2. Engine driven PM brushless generators are rather avoided due to difficulties with shutting down the power in failure modes. A generator control unit (GCU), or voltage regulator, is used to control generator output. The generator shaft is driven by a turbine engine with the aid of gears or directly by low spool engine shaft.

Since the speed of an aircraft engine varies from full power speed to flight idle speed (typically 2:1), and frequency is proportional to the generator rotational speed,

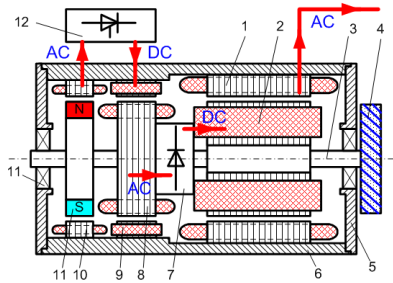

Figure 1.2: Architecture of a three-machine synchronous generator set. 1 – three-phase stator (armature) of main generator, 2 – salient-pole rotor with field excitation winding of main generator, 3 – shaft, 4 – toothed wheel of step-down gear, 5 – end bell, 6 – housing, 7 – rotating diode rectifier, 8 – three-phase rotor (armature) of exciter, 9 – stationary field excitation system of exciter, 10 – three-phase stator (armature) of subexciter, 11 – PM rotor of subexciter, 11 – bearing, 12 – GCU [23, 35].

a device for converting a variable speed to constant speed is necessary [35]. The so called *constant speed drive* (CSD), i.e., a complex hydromechanical device was common until the late 1980s [35]. Nowadays, solid state converters have replaced unreliable CSDs with *variable speed/constant frequency* (VSCF) systems.

1.2 TU-154M POWER SYSTEM

The main power supply system of the Tu154M is a three-phase 115/200V, 3×40 kVA, 400 Hz, AC system [19, 49]. The three-phase 115/200 V AC power is delivered by three GT40PCh6 wound-field synchronous generators. The fourth GT40PCh6 AC generator is the APU generator. The APU is also equipped with 27 V DC GS-12TO starter-generator.

The secondary three-phase, 36 V, 400 Hz, 46.8-A, 2×3 kW AC system takes power from the main system via two three-phase 206/37 V, Dy, TS330S04B transformers. The primary windings of TS330S04B transformers are fed from the navigation piloting system (NPK) bus bars. The 115/200 V AC and 36 V AC power system are shown in Fig. 1.3 and described in Table 1.1. The third power system is the 27 V, 200 A, DC, single-circuit system (Fig. 1.4), which receives power from the main system via transformer and three VU-6A rectifiers and four 20NKVN-25 batteries.

The emergency 36 V AC power system (instead of RAT) consists of 20-30/36 V, 400 Hz, 250 VA two PTS-250 transistor inverters fed from batteries. It feeds among others the gyro horizon AGR-144. Another single-phase 115-V emergency system takes electric power from batteries via POS-125TCh solid state

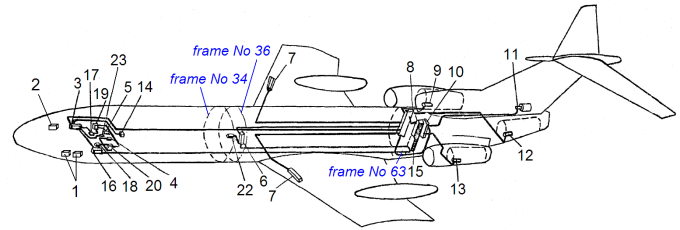

Figure 1.3: Main power distribution systems 115/220 V AC and 36 V AC of Tu-154M. 1 - rectifiers VU-6A (backup and No 1), 2 - rectifier VU-6A No 2, 3 - right junction box (JB) 115/200 V, 4 - converter PTS-250 No 2, 5 - converter PTS-250 No 1, 6 - JB of kitchen, 7 - JB of anti-ice system, 8 - right panel of generators, 9 - generator GT40PCh6 No 3, 10 - JB of APU 200 V, 11 - generator GT40PCh6 of APU, 12 - generator GT40PCh6 No 2, 13 - generator GT40PCh6 No 1, 14 - external power connector for ShRAP-400-3F GPU, 15 - left panel of generators, 16 - left JB 115/220 V, 17 - transformer No 2, 18 - transformer No 1, 19 - right JB 36 V AC, 20 - left JB 36 V AC, 22 - flight attendant switchboard, 23 - converter POS-125TCh [49].

converter. The simplified electrical diagram of the 115/200 V AC electric system is shown in Fig. 1.5. The block diagram of overall electric system of the Tu-154M is shown in Fig. 1.6.

1.3 ELECTRIC POWER DISTRIBUTION

The main three-phase, 115/200 V, 400 Hz power supply system is a three-channel system (Figs 1.3 and 1.5). One GT40PCh6 generator feeds one channel (electric grid).

The generator No 1 mounted on the left turbofan engine No 1 feeds the grid No 1, which in turn feeds the left autonomous bus bars, left bus bar of navigation piloting system (NPK), radio navigation equipment, anticollision flashing lights SMI-2KM, control systems of slats and stabilizers (motors No 1), fuel pumps No 1,3,5,8,10, rectifiers VU-6B No 1 (No 3), passenger cabins lighting, heaters of windshields of cockpit, hydraulic pumping station NS-46 of the second hydraulic system, and other loads. The total power consumption of the grid No 1 is 23.2 kVA, 70 A (excluding NS-46).

The generator No 2 of the grid No 2 mounted on the center engine No 2 feeds anti-ice electric heating elements of leading edges of wings (slats). The power consumption is 43.6 kVA, 130 A.

The third grid No 3 powered by the generator No 3 installed on the right engine No 3 is loaded with the right autonomous bus bars, right bus bar of navigation piloting system (NPK), control system of slats and sta-

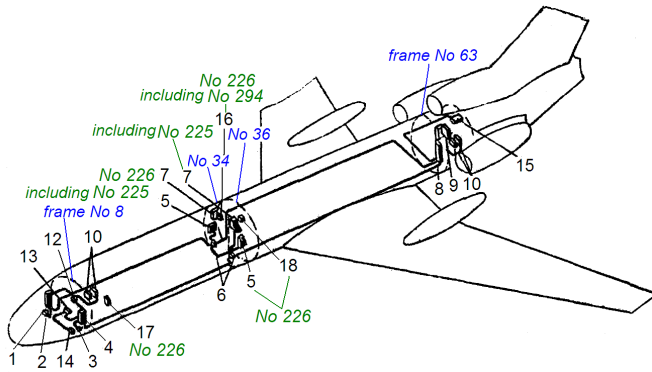

Figure 1.4: Power distribution system 27 V DC of Tu-154M. 1 – Rectifier VU-6A No 2, 2 – right panel of protection control, 3 – Rectifier VU-6A No 1, 4 – Left panel of protection control, 5 – junction box (JB) of kitchen, 6 – left power JB 27 V DC, 7 – electrical panel of flight attendant, 8 – rear JB (in left panel of generators), 9 – JB of APU and batteries, 10 – batteries 20NKBN-25, 12 – JB of batteries, 12 – JB of backup VU-6A rectifier, 14 – backup rectifier VU-6A, 15 – “PT” JB, 16 – electrical panel of household devices, 17 – electrical panel of crew dashboard, 18 – flight attendant switchboard [49].

bilizers (motors No 2), fuel pumps No 2,4,6,7,9,11, fuel control system, rectifiers VU-6B No 2 (No 3), air conditioning system, hydraulic pumping station NS-46 of the third hydraulic system, household equipment and other equipment. The total power consumption is 12 kVA, 45 A (without household equipment and NS-46). The household equipment needs 13 kVA, 60 A.

In the case of failure of one of the generators, its grid is automatically reconnected to the operating generators.

The GPU supplies all three electric grids. After starting any turbofan engine and after switching on any GT40PCh6 generator, the first and the third grid is automatically connected to this generator while the GPU feeds only the second grid. If two generators are on, the GPU is automatically disconnected from the aircraft electric power system.

Control and protection devices of the main power system are located on the power panel of the flight engineer. The three-phase 36-V, 400-Hz, two-channel electric power system feeds the Kurs-MP-2 landing navigation and control unit, ARK-15M radio compass, Groza-154 radar, Doppler effect velocity and drift angle measure system DISS-3P, hydraulic pressure gauge MET-4B. The 36 V AC system also supplies the gyro horizon (attitude indicator), but its power is supplied independently of the PTS-250 converter, which receives electrical energy from batteries. The PTS-250 No 1 converter is used as an emergency 36 V AC power source (Fig. 1.6).

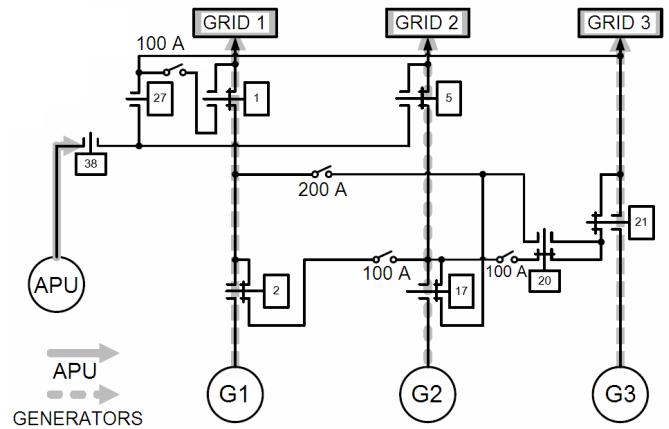

Figure 1.5: Simplified schematic of main electric power system 115/220 V AC when all generators G1, G2, and G3 are in parallel. 1 – contactor TKS133DOD “reconnection of grid No 1 on generator No 3”, 2 – contactor TKS233DOD “switching generator No 1 on grid”, 5 – contactor TKS233DOD “switching APU on grid No 2”, 17 – contactor TKS233DOD “switching generator No 2 on grid”, 20 – contactor TKS233DOD “reconnection of grid No 3 on generator No 1”, 21 – contactor TKS233DOD “switching generator No 3 on grid”, 27 – contactor TKS233DOD “switching APU or GPU on grid No 3”, 38 – contactor TKS233DOD “switching APU on grid” [30].

Connection of the converter to the network is made automatically.

The on-board 27 V DC power system consists of three VU-6A rectifiers, GS-12TO starter-generator mounted on the APU, and two four 20NKVN-25 batteries (Fig. 1.4). The VU-6A rectifiers are the basic DC power sources. They get the power from the first and third grid (from the main 115/200 V AC system). There are two basic rectifiers and the third rectifier is for redundancy (Fig. 1.6). The third rectifier is switched on automatically in the case of failure of one of the basic rectifiers and operates in parallel with the remaining rectifiers. There is also provision for “forced” connection of the third reserve rectifier.

The 27 V DC GS-12TO APU-mounted starter-generator delivers power to the DC grid after starting the APU on the ground until turbofan engines are started and GT40PCh6 synchronous generators operate. *In the case of failure of the main 115/200 V power system in the air, rechargeable batteries are used to supply the most important loads* (Section 1.4.3) and to start the APU on the ground in the absence of GPU. Under normal operation, batteries are connected in parallel to smooth the DC bus voltage ripple. Rechargeable batteries are

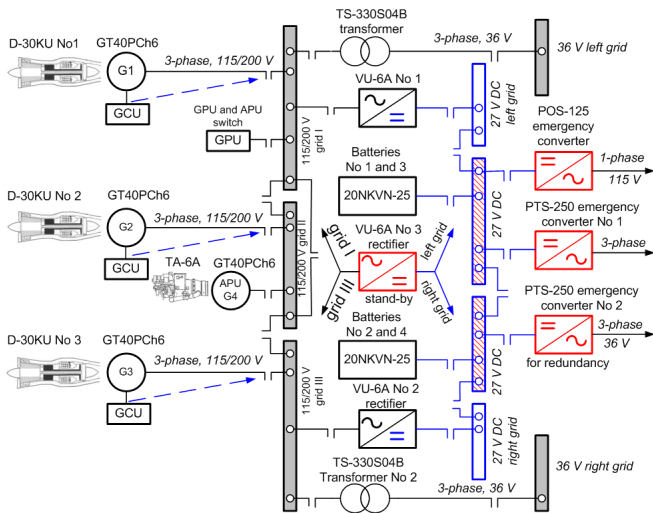

Figure 1.6: Block diagram of electric power system of Tu-154M [54].

installed in the rear fuselage under the floor of the technical compartment. They can be accessed through a removable hatch in the floor.

In addition, there is a 27 V AC power supply designed for household appliances: electric kettles and electric warmer in the kitchenette-buffet. The system gets its power from the main system through a TS-330S04A transformer connected to the grid No 3 via a switch mounted on the flight attendant switchboard (Figs 1.3 and 1.4). The transformer is installed on the right board, near the frame No 35, in junction box (JB) of the kitchenette (Fig. 1.3).

The single-phase 115 V AC, 400 Hz power supply provides electric power to Landish-20 FM radio station, radio system RSNB-2SA of near-range navigation, Kurs-MP-2 navigation and control unit, and other radio equipment, as well 2IA-7A temperature meters of engine exhaust gases. In the case of emergency, the electrical power to these loads comes from the converter MA-100M, which is supplied from batteries. The connection of inverter is made automatically.

The lighting equipment of the Tu-154M consists of external and internal equipment. External equipment is intended for taxiing, takeoff, landing, and indicate the plane in the air space at night. Interior equipment is used for illumination of cockpit, passenger cabin and other compartments of aircraft, and emergency lighting.

The external lighting equipment includes wing navigation (position) lights BANO-57 with 70-W SM-28-70 lamps, 115-V, 45 flare/min SMI-2KM anticollision flashing lights, and 27-V, 35.5 A PRF-4 landing/taxi lights.

The cross section of basic distribution wires is:

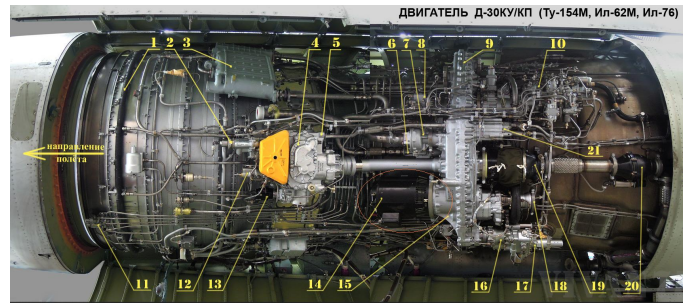

Figure 1.7: Turbofan engine D-30KU. 1 – inlet guide vanes heating collector (VNA), 2 – centrifugal air separator of oil system, 3 – fuel-oil heat exchanger, 4 – main oil pump, 5 – front (main) accessory drive gearbox, 6 – hydraulic pump for thrust reverse, 7 – fuel pump, 8 – sensor of referred revolutions, 9 – place for aircraft hydraulic pumps NP-25 and NP-89, 10 – fuel pump regulator, 11 – temperature sensor, 12 – centrifugal regulator of low pressure (LP) rotor, 13 – rotational speed sensor for the LP rotor, 14 – synchronous generator GT40PCh6, 15 – rear accessory drive gearbox, 16 – constant speed drive (CSD), 17 – mechanism of frequency correction, 18 – air turbine of CSD, 19 – air turbo starter, 20 – overlapping cover of turbo starter, 21 – oil removal pump.

<http://commons.wikimedia.org/wiki/File:D-30KU-jet-engine.jpg>

- 1.93 to 35.0 mm² for AC systems
- 1.5 to 70.0 mm² for DC systems

1.4 ABNORMAL OPERATION OF ELECTRIC POWER SYSTEM

1.4.1 Failure of one generator or engine When one generator GT40PCh6 or engine does not operate and the anti-ice electric system of slats is on, the following loads can be switched on

- in flight – one hydraulic pumping station NS-46 without any restrictions;
- at landing – one hydraulic pumping station NS-46 provided that grids No 1 and 3 are loaded below 110 A.

Under heavier loads (current exceeding 110 A) some loads must be disconnected, i.e., fluorescent lamps of passenger cabins, fuel pumps of tanks No 2, 3 and 4, while engines are fed only with fuel from the collector tank No 1, and Groza-154 radar. When the NS-46 hydraulic pumping station is on, it is necessary to monitor the generator current not allowing to exceed 138 A.

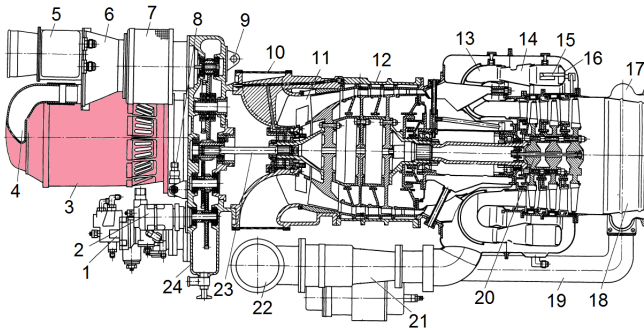

Figure 1.8: APU with GT40PCh6 synchronous generator and TA-6A turboshaft engine. 1 – fuel pump-regulator, 2 – sensor of tacho generator, 3 – synchronous generator GT40PCh6, 4 – leads of synchronous generator, 5 – air-oil heat exchanger, 6 – adapter, 7 – fan, 8 – stabilizer of oil pressure, 9 – front suspension rigging, 10 – grid of compressor, 11 – radial-circular entrance, 12 – compressor, 13 – gas collector, 14 – combustion chamber, 15 – evaporation tube, 16 – head of flame tube, 17 – snail, 18 – exhaust pipe, 19 – air bypass pipeline, 20 – turbine, 21 – air regulator, 22 – bleed air pipe, 23 – spring, 24 – reducer [19].

1.4.2 Failure of two generators or engines In the case of failure of any two generators GT40PCh6 or turboshaft engines, the sequence of switching on the NS-46 hydraulic pumping stations is the same as in the case of failure of only one generator (engine) when the anti-ice electric system of slats is connected, but it can be fed only from the APU GT40PCh6 generator.

1.4.3 Failure of all three generators or engines If all three GT40PCh6 generators must be shut down (fire or fume coming out of electrical equipment), it is allowed on aircraft with autonomous bus when hydraulic pumping station must operate to switch on one of the generators provided that the emergency switch of the active generator is disabled.

When all three generators do not work, the electric power is supplied from the following sources [19, 54]:

(a) Batteries

- emergency converters 115 V AC and 36 V AC;
- engine starting system in the air;
- fire extinguishing system;
- valves that connects hydraulic systems to steering drives (boost control), valve charging the hydraulic accumulator of emergency braking;

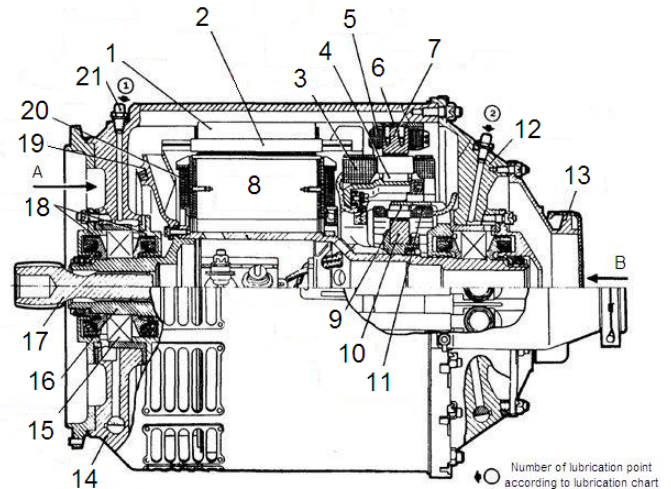

Figure 1.9: Wound-field air-cooled synchronous generator GT40PCh6: 1 – armature core of main generator, 2 – armature winding of main generator, 3 – armature winding of exciter, 4 – armature core of exciter, 5 – field winding of exciter, 6 – pole, 7 – field excitation system of exciter, 8 – rotor pole of main generator, 9 – armature of subexciter, 10 – PM, 11 – armature winding of subexciter, 12 – end shield, 13 – nozzle, 14 – housing, 15 – bearing, 16 – hollow shaft of rotor, 17 – shaft end, 18 – flanges, 19 – fan, 20 – field winding of main generator, 21 – point of lubrication. <http://s010.radikal.ru/i314/1010/42/cba147b70185.jpg>

- management of inner and middle spoilers and lights indicating their position;
- manual control of flaps;
- control of main and front landing gears;
- control and trim of enroute load feel mechanism (rudder and elevator);
- correction switches VK-90 No 1 and 4 of gyro horizon;
- valves of bleed air in the case of NK-8-2U turboshaft engines¹, pressurization valves, pressure relief from pressurized cabin, backup system of pressure control, gauges of air temperature in passenger cabin and pipelines;
- valves of switching anti-ice system of turboshaft engines and air intakes of wings and tail;
- anti-ice system of gauges of full pressure (PPD);

¹only on Tu-154, Tu-154A, Tu-154B, Tu-154B1 and Tu-154B2 aircraft.

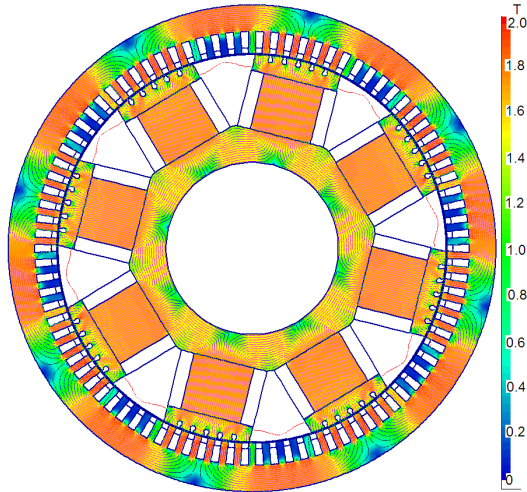

Figure 1.10: Magnetic flux distribution in the cross section of GT40PCh6 synchronous generator as obtained from the 2D FEM. Author's simulation at the University of Technology and Life Sciences, Bydgoszcz, Poland.

- radio compass ARK-15M;
- accurate direction (heading) system TKS-P2 (channel No 1);
- aircraft intercom SPU-7, SGU-15, on-board voice recorder MARS-BM;
- Baklan No 1 and 2 radio stations;
- flight data catastrophic recorder MSRP-64;
- indicators of oil level, tachogenerators of engines, outside temperature indicators;
- light and sound signaling;
- headlights and aircraft navigation lights (ANO);
- illumination of cockpit;
- APU fuel pumps ECN-319 (27 V DC);
- “exit” sign lights, emergency lights of passenger cabin, restrooms and lobbies;
- display of flight azimuth and turning the aircraft around its vertical axis;
- relief valves of the air of pressurized cabin.

(b) Emergency 115 V AC POS-125Ch solid state converter

The emergency 115 V AC POS-125Ch converter feeds only only indicators of gas temperature behind the turbines of engines.

(b) Emergency 36 V AC PTS-250 No 1 transistor inverter

Table 1.1: AC power systems of Tu-154

Voltage, V	115/220	36
Number of phases	3	3
Nominal power of the system	120 kVA	6.0 kW
Number of channels	3	2
Nominal power per channel (one generator)	40 kVA	3.0 kW
Maximum power per channel	50 kVA	3.75 kW
5-min overload power	60 kVA	4.50 kW
5-s overload power	80 kVA	6.0 kW
Frequency, Hz	400	400
Nominal current per channel, A	111	46.8
Maximum current per channel	138	58.0
Power factor	0.8 to 1.0	0.8

- backup gyro horizon (attitude indicator) with VK-90 correction switch;
- radio compass ARK-15M;
- pressure gauges of hydraulic system;
- indicator of direction angles IKU-1A installed on the dashboard of the aircraft commander and navigator;
- compact vertical gyro MGV No 1 (to determine the spatial position of the aircraft in roll and pitch).

(b) Emergency 36 V AC PTS-250 No 2 transistor inverter

- accurate direction (heading) system TKS-P2 (channel No 2);
- flight data catastrophic recorder MSRP-64;
- first subchannel of trimming enroute load feel mechanism (rudder and elevator).

1.5 SYNCHRONOUS GENERATORS

The main generators are three CSD 40-kVA, 115/200 V, 400 Hz GT40PCh6 wound-field synchronous generators driven by three D-30KU turbopfan engines (Fig. 1.7). Each generator feeds one channel. The reserve 40-kVA, 115/200 V, 400 Hz power source, the so called APU consists of GT40PCh6 synchronous generator driven by independent TA-6A turbine engine (Fig. 1.8). The Tu-154M is not equipped with the RAT emergency wind turbine.

The longitudinal section of the GT40PCh6 synchronous generator is shown in Fig. 1.9. From better

Table 1.2: Parameters of GT40PCh6 synchronous generator

Stator	
Number of phases	3
Rated speed, rpm	6000
Rated frequency, Hz	400
Stator phase voltage, V	115
Stator rated current, A	111
Armature winding resistance per phase at 25°C, Ω	0.0264
Base impedance, Ω	0.9919
d -axis synchronous reactance, p.u.	1.954
q -axis synchronous reactance, p.u.	0.776
Rotor	
Type of rotor	salient pole
Pole arc-to-pole pitch ratio	0.58
Number of poles	8
DC field current at nominal load and PF=0.75, A	45.58
Total moment of inertia, kgm^2	approx. 0.06

packaging point of view, the PM brushless subexciter is placed inside the exciter.

The GT40PCh6 generator operates smoothly under the following conditions:

- ambient temperature from +100 to -60°C ;
- cooling air temperature from +60 to -60°C ;
- atmospheric pressure up to 124 mm Hg;
- effects of frost and dew;
- shock accelerations up to $6g$.

The housing monoblock is made of magnesium alloy with pressed steel sleeve mounted on the drive side around the ball bearing. The bearing nest has a pocket for the collection of waste grease that is removed from it with the aid of a plunger. Lubricant is applied to the bearing on the oil line through the point of lubrication.

There are longitudinal ribs on the inner surface of the housing, which increase its rigidity and form channels for passage of cooling air. Windows in the enclosure at the drive side are designed to exit the air. A titanium flange screwed to the end shield mounts the generator on the engine. A box on the outer surface of the housing contains a differential current transformer for protection of the generator.

The rotor has two ball bearings. Seals of the bearings are of threaded type with extra cuffs. The rotor salient

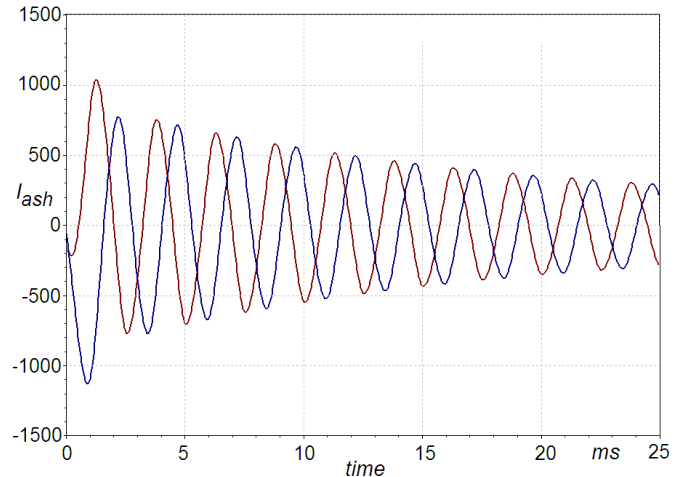

Figure 1.11: Armature current I_{ash} at two lines-to-neutral short circuit of GT40PCh6 synchronous generator. The peak short-circuit current is $I_{ashp} = -1130$ A corresponds to $t = 0.6$ ms [20].

poles, armature of the exciter and PMs of subexciter are pressed on the hollow shaft. The rotating rectifier consists of six D232A silicon diodes.

Cooling of the generator is accomplished by blowing air at a flow rate varying from 0.1 to 0.3 kg/s [19].

Dimensions, material data and winding diagrams of the GT40PCh6 synchronous generator are not available [19, 44, 49, 54]. To obtain dimensions, winding parameters and detailed performance characteristics of GT40PCh6 synchronous generators (Table 1.2), a reverse design on the basis of available sources [19, 44, 49, 54] has been done. The 2D FEM has been used for electromagnetic synthesis and analysis [20]. The 2D magnetic flux distribution in the cross section of the GT40PCh6 main generator is shown in Fig. 1.10. The obtained short-circuit current waveforms, e.g., Fig. 1.11 are very important since the subtransient and transient short-circuit currents help to evaluate the possible damage during the electrical power system failure.

Short-circuit currents can exceed more than 11 times the nominal current. The most dangerous is two lines-to-neutral short circuit (Fig. 1.11).

1.6 FAILURES OF SYNCHRONOUS GENERATORS

The mean time between failures (MTBF) of GT40PCh6 synchronous generators is estimated as approximately 8500 to 9000 flight hours [19, 30, 49, 54].

There is known at least one case of main generator failure, i.e., the Tu-154B2 RA-85588 while operating flight 7K 348 on January 1, 2011 from Surgut (located



Figure 1.12: Tail part of Tu-154B2 RA-85588 after fire at Surgut airport on January 1, 2011 [30].

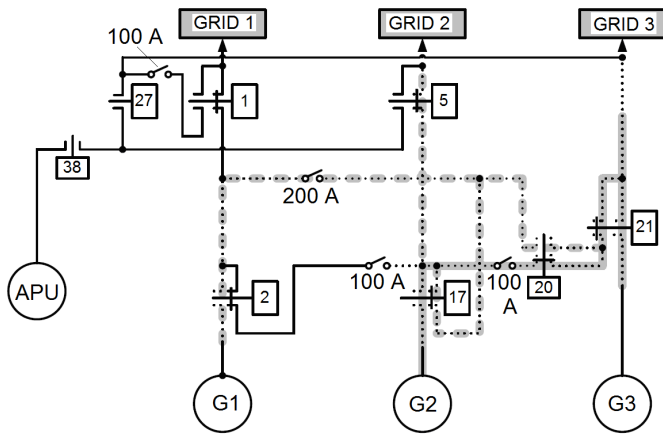

Figure 1.13: Closed electric circuit on assumption of abnormal scenario corresponding to the 21st contactor TKS233DOD “switching generator No 3 on grid” [30].

on the Ob River near its junction with Irtysh River) to Moscow (Domodedovo). The plane was taxiing to the runway while preparing for its takeoff from Surgut when the right engine caught fire on the taxiway (Fig. 1.12). Three out of 126 passengers and 8 crew members died.

Russia’s Interstate Aviation Committee (MAK) released their final report (in Russian) concluding the probable cause of the accident was the outbreak of fire in the right generator panel located between frames 62 and 64 in the cabin [30]. The generators were connected on the network after the engine start and exit to the idle mode. The cause of the fire was an electrical arcing produced by electrical currents exceeding 10 to 12 times the nominal current when two generators not synchronized with each other were brought online but got



Figure 1.14: Emergency landing of the Tu-154M RA-85684 at abandoned air strip near town of Izhma on September 7, 2010. The impact was damped by the young trees which have grown since the airport was closed. The photograph shows the right wing that cut a pine tree [46].

connected together instead of being connected to parallel busses (Fig. 1.13). Under such conditions the currents can reach more than 10 times the nominal current of the generator. The unsynchronized operation of the generators can be attributed to:

1. Poor technical conditions of contacts TKS233DOD (Fig. 1.13) responsible for connecting the generators with the electrical busses, that were damaged by prolonged operation without maintenance. A contact normally open was welded and fractured insulation material moved between contacts that are normally closed. These abnormal contact positions led to the connection between No 2 and No 3 generators (Fig. 1.13).
2. Differences in the schematic diagrams of generator No 2 and generators No 1 and 3. When the switch is moved from “check” to “enable” with no delay in the “neutral” position, the generator 2 is brought on line without time delay. This leads to increased wear of normally closed contacts in the TKS233DOD unit. The specific design of the electrical systems ensures power supply to each bus from either the APU or engine integrated drive generator.

In the report [30] there is no evidence that the short circuit current (Fig 1.11) under unsynchronized operation has been calculated including actual conditions during the incident. It was rather estimated on the basis of engineering practice or obtained from the manufacturer of generators.

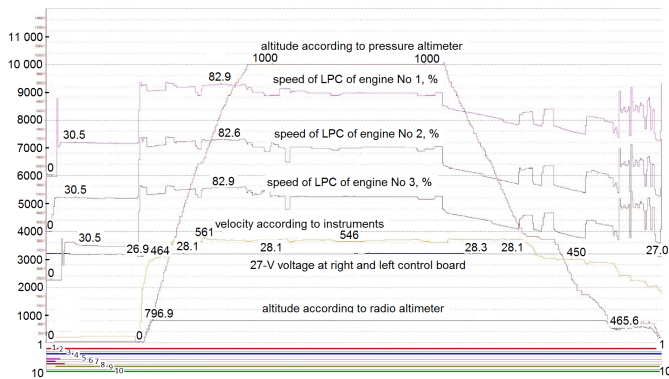

Figure 1.15: Parameters of flight of the Tu-154M No 101 for electrical equipment and engines on April 10, 2010, 7:14 – 8:41 am. LPC = low pressure compressor. Description in Table 1.4 [14, 15].

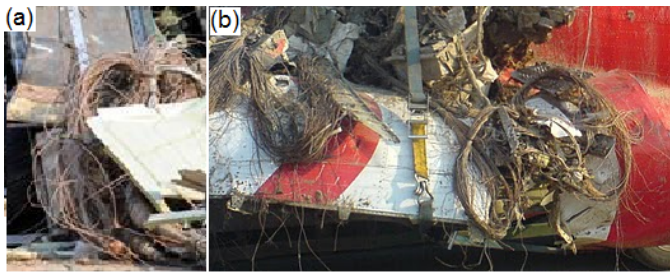

Figure 1.16: Electric wires scattered throughout the Tu-154M No 101 wreckage: (a) at the crash site (beside spare landing gear wheel); (b) hanging from heavy transportation vehicle.

1.7 FAILURES OF OTHER ELECTRICAL EQUIPMENT

On September 7, 2010, the Tu-154M RA-85684 Alrosa Mirny Air Enterprise Flight 514 aircraft from Udachny (located 1370 km northwest of Yakutsk on the Markha River) to Moscow suffered a complete electrical failure *en route*, leading to a loss of navigational systems. The electrically operated fuel transfer pumps were also affected and prevented transfer of fuel from the wing tanks to the engine supply tank in the fuselage.

After emergency descent below cloud level the crew were able to spot an abandoned air strip near town of Izhma (Fig. 1.14). The abandoned air strip is 1325m, whereas the Tu-154 requires a minimum of 2200 m. The aircraft landed at a speed of 350 to 380 km/h, faster than normal, due to the lack of flaps. Although the flaps are powered by hydraulics, the switches operating them are electrical. All 9 crew members and 72 passengers evacuated using the aircraft's evacuation slides. No injuries were reported.



Figure 1.17: Junction and control boxes of electrical installation. Photo taken at the site of wreckage storage [16].



Figure 1.18: Generator GT40PCh6 on No 1 (left) D-30KU turbofan engine. Photo taken between 11 and 13 April 2010 on the crash site [15].

On November 17, 1990, the cargo TU 154M, SSSR-85664 of Aeroflot Airways was heading through Czech territory with a load of Winston cigarettes from Basel (Switzerland) to Moscow. A switched-on cooker in the kitchenette caused a fire on board of the plane and the crew decided to land at the closest possible place. The crew made an attempt of emergency landing on the field near Dubenec village in the East Bohemia. There were only 6 crew members on board, all of them survived the air disaster.

On February 18, 1978, the Tu154A, SSSR-85087 of Aeroflot Airways was standing on the apron at Tolmachevo Airport, Novosibirsk. The cabin heater was left working unattended between flights. A rag caught fire, which incinerated the cabin. A fire that broke out in the passenger cabin engulfed the rear part of the airframe. The forward fuselage burnt out. There were no fatalities.

Table 1.3: Examination of electrical equipment at crash site

Electric equipment	Standard procedure [18, 53]	Evidence of examination by IAC (MAK) [29] and/or CINAC (KBWL) [13]
Electrical wiring	Visual inspection of conductors and insulation.	Probably
Circuit breakers, switches and relays	Inspection if contacts are free of metal flow and excessive cratering caused by arcing	No evidence
Electric generators and motors	1) Visual inspection 2) Measurements: winding resistance and inductance, insulation resistance 3) Machine taken apart: are there any scores and scratches on the inner surface of the stator core, is the shaft bent, what is the condition of bearings?	1) Probably 2) No evidence 3) No evidence
Feeders and buses	Testing for tightness, evidence of arcing and erosion of terminal studs, evidence of foreign objects.	No evidence
Light bulbs	Examination of glass envelope, filament and evidence of powder inside the glass envelope.	Some incandescent light bulbs, e.g., illumination bulbs (filaments) of PU APK-15M automatic radio compass were examined by Russian IAC (MAK) [29]



Figure 1.19: Electromagnetic brake TEM-4 for flap control found several meters behind the famous birch tree. Source: <http://www.waronline.org>

1.8 INVESTIGATION OF ELECTRICAL EQUIPMENT AND WIRING AFTER CRASH

Electrical events happen at the speed of light. Aircraft crash at much lower speed and a lot can happen to electrical system between the first collision with ground or terrain obstacle and complete stop [53]. The state of electrical circuit can change in this very short time interval: circuits, which were “on” at initial impact are “off”

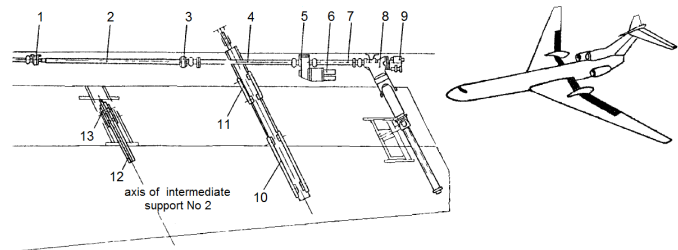

Figure 1.20: Location of electromagnetic brake TEM-4 for flap control. 1,3 – bracket, 2,4 – transmission shaft, 5 – reducer, 6 – electromagnetic brake TEM-4, 7 – cardan joint, 8 – lift for the outer flap, 9 – mechanism of limit switches with sensor, 10 – rail of external deflector, 11 – carriage of external deflector, 12 – rail of deflector, 13 – intermediate carriage of deflector [48].

when the wreckage finally comes to stop. Finding the evidence of short circuit or electric arc does not mean that the electrical malfunction has occurred before the accident. It could rather happened during impact.

Before inspection of the wreckage it is recommended to do a homework [18, 53]: i.e.,

- interviewing witnesses (crew members, passenger, outsiders),
- familiarizing with air-to-ground communication, flight data recorder (FDR) and cockpit voice recorder (CVR) data, if available, e.g. Fig. 1.15.

Table 1.4: Parameters of electrical equipment plotted in Fig. 1.15.

No	Polish acronym	Description
1	TABLEAZS27V	27 V is on the left board AZS (automate of grid security)
2	STARTWSU	Engine starter is switched-on
3	SZYNAWA36	36 V is on the right bus of PTS-250 No 1 DC to AC converter
4	NPKP1SIEC3	NPK (navigation piloting system) bus is switched from the right grid No 3 to the left grid No 1
5	G1NIESPR	Generator No 1 is disconnected from the grid
6	G2NIESPR	Generator No 2 is disconnected from the grid
7	G3NIESPR	Generator No 3 is disconnected from the grid
8	SIECPR36V	36 V is on the right bus
9	NPKL1SIEC3	NPK bus is switched from the left grid No 1 to the right grid No 3
10	LSIEC36V	Emergency voltage 36 V is on the left bus of PTS-250 No 2 DC to AC converter

Evidence in the recordings or statements that some electrical parts and systems were operating correctly prior to impact is more credible than examination of the wreckage and saves investigators a lot of work [18, 53]. If witnesses and recordings are not available, the recommended approach to investigation of wreckage is to prove that the *electrical power was available on the front end and that electrical devices were operating on the rear end* of the aircraft (Table 1.3).

1.8.1 Electrical wiring Typical aircraft have from 16 to 160 km of wire installed such that wire from one system is often collocated with wire from many other systems. Electrical wiring can be classified into power wiring (heavy current) and light current wiring. In modern aircraft, power wires, feeding e.g., electric motors, are not routed through the cockpit. Switches in the cockpit are connected to light current wires (control wires), which active relies of heavy current circuit.

After crash, wiring is normally scattered throughout the wreckage, but major wire bundles remain more or less intact (Fig. 1.16).

Wiring is inspected visually. The condition of wires and their insulation is a good indicator of the source of overheating. External overheating discolor or burn the insulation, while the wire strands should be intact and shiny. Internal or severe external overheating discolor the wire strands.

Older aircraft design allows circuits from multiple systems to be co-bundled along shared raceways in the fuselage. This is cost-effective solution, but deterioration of insulation, overheating or arcing of one circuit can also damage to neighboring wires. For example, short circuit in a wire bundle was a root cause of ignition of the flammable fuel/air mixture in the center wing fuel tank (CWT) of Boeing 747-131 (flight TWA 800) on July 17, 1996.

1.8.2 Circuit breakers Circuit breakers protect the wiring, not equipment. Most circuit breakers are thermally activated. Arcing in the line does not always open the circuit breaker. However, circuit breakers may open under impact forces.

1.8.3 Electric generators Generators stator winding resistances and inductances should be measured for possible open or short circuits. Also, the resistance between winding terminals and housing should be measured for possible damage to insulation. After external examination and basic electrical measurements, the generator should be taken apart to check for any evidence of scratching on the inside surface of the stator core, bearing failure, bent shaft and insulation overheating. Scoring and scratching on the stator core indicate if the generator was spinning or not before the crash.

1.8.4 Generator feeders Terminals of buses should be tested for tightness, evidence of arcing and erosion of terminal studs, corrosion and foreign objects being in contact with the terminals [18].

1.8.5 Emergency power supply Emergency power supply includes batteries, APU and RAT (not installed on the Tu-154). If one of the main generators fails, there is usually the possibility to connect the inoperative circuit to an operative one (Section 1.4).

1.8.6 Electric loads Electrical loads include various electric motors and actuators, lights, de-icing, anti-icing, kitchen equipment, navigation instruments, flight instruments, communication equipment, radar and electronics. Similar to generators, the evidence of scrolling, scoring and scratching on the inside of the stator core of the motor indicates if the electric motor was spinning or not before the impact. Damage to electronic equipment is

difficult to determine whether it was done before or after the impact.

1.8.7 Light bulbs analysis Analysis of light bulbs in the cockpit can tell which lights were on or off at impact. When a tungsten filament burns, it leaves a grayish powder, i.e., the tungsten oxide. When the remaining parts of the bulb are coated with grayish powder, the bulb was probably on at the time the glass envelope broke. When the glass envelope was broken and no grayish powder was produced, any evidence of changing the color of filament (from yellow to red to purple to blue) shows that the bulb was probably on. If the color of filament remains unchanged, the bulb was probably off. Broken glass envelope and intact filament indicates that the bulb was definitely off.

1.9 EXAMINATION OF ELECTRICAL EQUIPMENT OF TU-154M ON CRASH SITE

Operation of electrical equipment and installation of the Tu-154M is monitored by the MSRP² flight data catastrophic recorder with the aid of parameters described in Table 1.4. Those parameters are plotted in Fig. 1.15 (color lines at the bottom).

The catastrophic recorder MLP-14-5 (part of MSRP) was found on April 10, 2010 by Russians. Data of MLP-14-5 were recorded in the IAC (MAK) headquarters in the presence of Polish military prosecutor on April 11, 2012 [15]. The recording medium (tape) was in good condition [15].

Annexure 4 [15] to the Report [13], Section 7.2 “Analysis of electrical installations” concludes that during the flight on April 10, 2010, the electric system operated correctly, i.e.:

- The main generators GT40PCh6 were connected to the grid immediately after starting the engines in the following sequence: engine No 2 – generator No 2, engine No 1 – generator No 1 and engine No 3 – generator No 3. During the flight, there were no signs of automatic or manual disconnection of any of the generators from the grid, which means that the electric system was operated in accordance with the technical guidelines.
- There were no signs of change of power supply configuration of the left and right navigation piloting system NPK buses. NPK buses were fed in accordance with the technical guidelines.
- There were no signs of starting the APU.
- There were no signs of the 36-V AC power system malfunction and no signs of automatic or manual

²Magnetic system of registration of parameters.

activation of the emergency power sources for this system.

- There were no signs of the 27-V DC power system malfunction. The voltage on the left bus was within the limits in accordance with technical guidelines and there was no signal of voltage decay on the left bus.

According to latest research of K. Nowaczyk of the University of Maryland [38, 39], the ATM QAR³ has recorded a damage to the left engine No 1 and synchronous generator No 1⁴. Both the 115/200 V and 36 V (LSIEC36) of the left grid dropped to zero before the ground impact (Table 1.4).

There is no evidence that other than visual inspection of electrical equipment and wiring (Table 1.3) has been done on the crash site [13, 15]. The following statement is given on p. 20/28 of Annexure 4 [15]: *Bundles of electrical wires torn apart (Fig. 1.16). Control boxes deformed. Enclosures of on-board batteries deformed. Some cells leaking.* The report shows photographs of wire bundles, control boxes (Fig. 1.17), synchronous generator GT40PCh6 on the turbofan engine No 1 (Fig. 1.18), batteries and other electrical equipment.

The object found at the crash site several meters behind the famous “armored” birch tree [13] and shown in Fig. 1.19 has been often incorrectly identified as a fuel pump. However, this is the electromagnetic brake TEM-4 used for control of flaps (Fig. 1.20).

1.10 CONCLUSIONS

Electric system of the Tu-154M aircraft is an outdated system typical for aircraft being designed in the 1960s. Main synchronous generators are air cooled generators. In comparison with liquid cooling systems, air cooling reduces the rated power and power density, i.e., *output power-to-mass* ratio of generators. Nowadays, modern VSCF wound-field synchronous generators are oil cooled with rated power up to 250 kVA [35].

Reversed design and analysis of GT40PCh6 main synchronous generators deliver important information on the steady-state and transient performance of these machines. Transient characteristics, especially short-circuit waveforms are very helpful in investigation of electric power system after crash.

Credibility of flight parameters for electrical equipment and installation (Fig. 1.15) is questionable. There

³On-board recorder of flight parameters manufactured by Advanced Technology Manufacturing (ATM) Avionics, Warsaw, Poland, <http://www.armavio.pl>.

⁴see also <http://niezalezna.pl/29053-tupolew-rozlecial-sie-w-powietrzu>, 28.05.2012.

is not enough information how the recorded parameters have been secured, extracted and analyzed [15].

It is now practically impossible to find out if components of the electric power system was operating correctly in the last seconds of air crash or not. According to [13, 15], the flight management system (FMS) lost electric power (memory freezing) at 10:41:05, i.e., at the time of collision with ground.

Table 1.3 shows standard procedure for examination of electrical equipment and installation after crash [18, 53]. The electrical equipment and wiring at the crash site was only inspected visually [13, 15]. There is still possible to examine synchronous generators and induction motors for fuel pumps and for other on-board equipment. However, the results of examination may not be credible since the wreckage was carelessly loaded on the trailers and then transported, unloaded and stored in open space without any caution.

fuselage skin to the outside, dismembered bodies⁵, torn off clothes as well as lack of crater and fuel fire suggest rather explosion in the air above the ground than ground impact [8, 10, 45].



Figure 2.1: Plane crash site on April 12, 2012. Source: Global Digital.

Part 2:

HYPOTHESIS OF EXPLOSION IN THE LEFT WING OUTER FUEL TANK OF TU-154M DUE TO ELECTRICAL IGNITION OF FUEL-AIR MIXTURE

2.1 INTRODUCTION

According to official investigations of the Smolensk air crash [13, 29], the cause of disaster was collision of the Tu-154M No 101 with trees while landing in dense fog. At the distance of 855 m before the threshold of runway and 63-m left from its center line, the left wing of the aircraft hit a birch tree with the trunk diameter of about 0.4 m at the height of about 6.6 m [9]. As a result, the tip of the left wing of 6.1-m long between the 27th and 28th rib has been severed. The first ground impact was 525 m before the threshold of the runway and 105-m left from its center line. The satellite photograph of the crash site is shown in Fig. 2.1. Distribution, scattering and shape of debris, characteristic opening of the



Figure 2.2: Comparison of the fuselage at the crash site on April 10, 2012 with burst gas cylinder: (a) the fuselage looks like burst from inside, the walls are split along its longitudinal axis and open to the outside (<http://krsk.sibnovosti.ru/incidents/103354-podrobnosti-krusheniya-tu-154-v-smolenskoy-oblasti>); (b) burst gas cylinder (http://www.scubaengineer.com/scuba_cylinder_videos.htm).

2.2 PROBLEM STATEMENT

According to Annexure No 4 [15], Section 4.10.3, *the lost of the left portion of the wing has caused the burst of the left fuel tank No 3, which is placed between ribs No 14 and 45*. The severance of the 6.1-m long tip of the left wing was between the ribs No 27 and 28.

Since the severance of the wing tip as a result of collision with about 0.4 m diameter live birch tree with many whorls [9] is rather impossible [1, 2], the problem should

⁵Only 28 bodies out of 96 could be identified without DNA tests.



Figure 2.3: Hypothesis of explosion in the left wing.

be stated in opposite way: *The burst of the left fuel tank No 3 caused the lost of the left portion of the wing.*

According to [45], the Tu-154M No 101 crash was due to two explosions in the air: one on the left wing (Fig. 2.3) and the second inside the fuselage. An *explosion is defined as an event leading to increase of pressure due to high explosives, combustion of dust, mist or gas in the air, loss of containment in high pressure vessels, nuclear reaction, etc.* [3]. Huge amount of small plane's pieces and their location on the ground (Fig. 2.1), fuselage split along its longitudinal axis (Fig. 2.2), rivets torn out⁶, lack of crater, etc., exclude the crash caused by the mechanical impact.

If the explosion on the Tu-154M was due to action of the third party, installation of explosive in the left wing was not necessary. Electric wiring for electricity supply to electric motors of fuel pumps installed in the left wing tank No 3 could be adequately prepared⁷. It is necessary to mention that alterations to Salon No 3 were made in Warsaw on April 6, 2010.⁸



Figure 2.4: Construction of the Tu-154 wing [52].

⁶A rivet was found in exhumed body of a victim.

⁷This is a separate problem.

⁸The number of passenger seats in Salon no 3 was increased from 8 to 18. Hangar No 21, in which alterations to Salon No 3 of the Tu-154M No 101 were made, has been recently demolished.



Figure 2.5: Left wing on the wreckage storage site: (a) effect of shock wave penetrating inside the wing [45]; (b) severed tip of the wing [16].

Possible reasons for explosion in the left wing include, but are not limited to:

- Ignition of fuel-air mixture due to static electricity build-up or arcing in electric wiring or electric equipment;
- Explosive present in the left wing.

The construction of the Tu-154 wing is shown in Fig. 2.4. Its main parts are 3 spars, the upper and lower panels and 45 ribs. Wing ribs are perpendicular to the axis of the third spar. The chambers in their center parts are sealed and used as fuel tanks [44, 50, 52]. The interior of a wing fuel tank of a large aircraft is visualized, e.g., on photographs published on Little Rock Air Force Base web site [6]

The remains of the left wing show the effects of a strong shock wave penetrating inside the wing [45]. There are no spars present between upper and lower skin, which might be an effect of explosion (Fig. 2.5).

2.3 SIMILAR AIR CRASHES AND FULL-SCALE TESTS

Similar air crashes are understood as those in which:

- the same aircraft or aircraft of very similar construction crashes;
- conditions (speed, kinetic energy of aircraft, ground impact, obstructions, etc.) of air crash are similar.

Very similar case to Tu154M No 101 air crash took place on July 26, 2002, about 05:37 eastern daylight time (EDT) at the Tallahassee Regional Airport (TLH), Tallahassee, FL [12]. The Federal Express (FedEx) flight



Figure 2.6: Wreckage of the Boeing 727-232F FedEx flight 1478 at Tallahassee Regional Airport (TLH). Source: <http://www.aero-news.net/images/content/commair/2003/fedex727crash07>



Figure 2.7: Boeing 727 after crash on Sonoran Desert with its fuselage ripped in two [47]. Compare with Fig. 2.1 .

1478, a Boeing 727-232F, N497FE, struck trees on short final approach and crashed short of runway 9. The airplane collided with trees in a right-wing-low, slightly nose-up attitude during the approach to runway 9, then impacted the ground, coming to rest on a heading of 260° about 474 m (1556 feet) west-southwest of the runway (Fig. 2.6). A postimpact fire ensued; however, the three flight crewmembers exited the airplane through the captain's side sliding cockpit window before the fire reached the cockpit [12]. The crash site shown in Fig. 2.6 cannot be compared to that shown in Figs 2.1 and 2.2a. The Tu-154M is conceptually similar to the Boeing 727, e.g., both aircraft use a rear engine T-tail configuration, S-duct for the middle (No 2) engine, similar leading edge sweep of wings, etc.

Recent full-scale experiment⁹ with a 170-seat Boeing 727 passenger aircraft in a remote and unpopulated

⁹UK Channel 4 and US Discovery Channel.

Sonoran Desert of Baja California, Mexico, has shown no fragmentation of the aircraft into small pieces under ground impact (Fig. 2.7) [47]. The objective was to recreate a serious passenger jet crash landing, so that scientist and engineers could study the impact of air crashes on the human body and aircraft structure. The pilot parachuted out of the cockpit at 762 m before the plane was plunged into the ground via remote-control by a pilot in a following Cessna. As the plane hit the ground with its speed of 225 km/h, the fuselage was torn in two with the nose embedded in the ground. Crash investigators predicted that 78% of passengers on board would have survived such ground impact. The TU-154M is a Russian copy of Boeing 727.

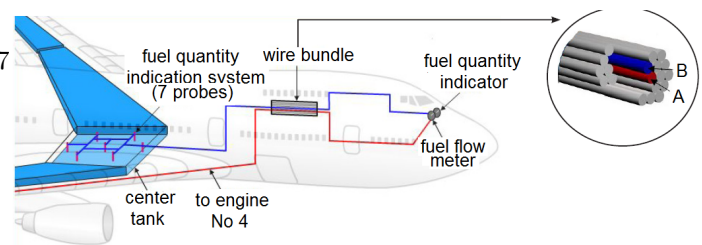

Figure 2.8: Wiring configuration on the Boeing 747. Investigators suspect that high voltage from the fuel flow meter A passed to the fuel quantity indication system (FQIS) B because of a short circuit in the wire bundle [34].

2.4 EXAMPLES OF EXPLOSIONS OF FUEL TANKS

In older (and also many new) types of passenger aircraft the electric wires belonging to different electric circuits are laid in common bundles [18, 53]. It is economical solution, which reduces the cost of electrical wiring. On the other hand, aging and deterioration of insulation, wire overheating, short circuit or electric arcing in one electric circuit can make damage to insulation and short circuit of wires belonging to other electric circuits. Thermal protections are sometimes not reliable. For example, short circuit in a bundle of electric wires caused ignition of fuel-air mixture in the center wing tank (CWT) of the Boeing 747-131, flight TWA 800 on June 17, 1996 (Fig. 2.8). Burst of CWT led to destruction of the aircraft over the Atlantic Ocean [34].

Explosion in the left wing fuel tank also took place on May 4, 2006 in Boeing 727-200 belonging to Malaysian Transmile Airline at Bangalore Airport, India [51]. Explosion destroyed the structural integrity of the left wing. Investigators have found damaged electrical installation and electrical arcing in aluminum tube with

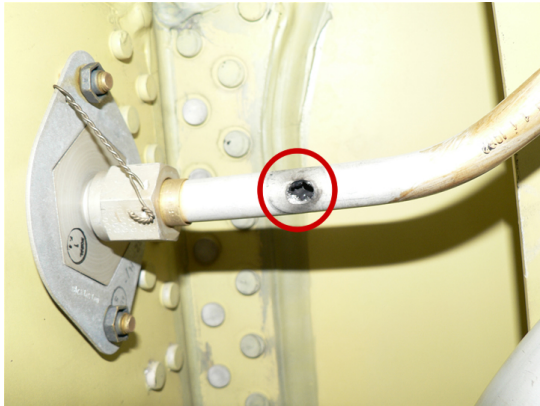

Figure 2.9: Evidence of electrical arcing of the wiring inside the exploded fuel tank of Boeing 727-200, Transmile Airlines, Bangalore, May 4, 2006 [51].

115-V AC cable feeding fuel pump motor in the left wing tank (Fig. 2.9).

2.5 TU-154M FUEL SYSTEM

Civil transport aircraft use the wing structure (Fig. 2.4) as an integral fuel tank to store fuel. In larger aircraft, the fuel is also stored in the structural wing box within the fuselage. A typical wing tank is irregular, long and shallow [35]. The fuel is in direct contact with the outside skin. The Tu-154M has six fuel tanks: one central fuel tank (CWT) No 1, two inner wing tanks No 2, two outer wing tanks No 3 and one additional tank No 4. The Tu-154M fuel tank configuration is shown in Figs 2.10 and 2.11. Tanks No 3 are between spars 1 and 3 and ribs 14 and 45 of detachable parts of wings [50].

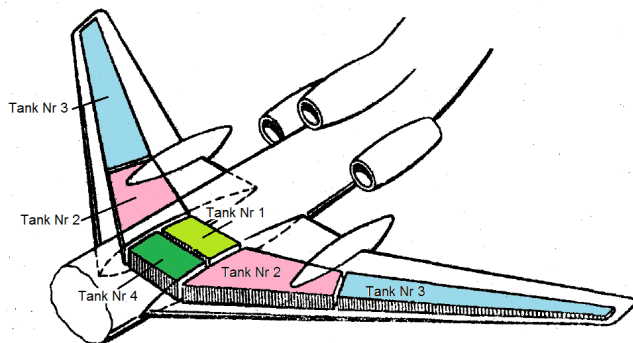

Figure 2.10: Tu-154M fuel tank configuration: No 1 – center wing tank (CWT), i.e., collector tank, No 2 – inner left and right wing tank, No 3 – outer left and right wing tank, No 4 – additional tank [50].

The CWT tank is generally categorized as hazardous due to the proximity to external heat sources, e.g., air-

conditioning units [35]. It requires *tank inerting* with the aid of nitrogen-enriched air from the on-board inert gas generating system. The tanks No 1 and 4 of the Tu-154M are inerted in the case of emergency landing without landing gears. The left and right wing tanks are usually categorized as nonhazardous as there is mostly no proximity of heat sources [35]. The wing leading edge slat section is equipped with anti-ice control system, typically with hot air ducts. These ducts take form of pipes with holes to allow air to heat the inner surface of leading edges. The hot air flow to the outer wing leading edges is controlled by the wing anti-ice valve [35]. The Tu-154M has *electric anti-ice control system* with heating elements embedded in slats. Malfunction of electric anti-ice control system can theoretically cause dissipation of heat in the vicinity of the wing fuel tank No 3 (Sections 2.6 and 2.7). According to [13], the electric anti-ice system of slats has not been activated during the flight Warsaw–Smolensk on April 10, 2010.

Table 2.1: Fuel pumps of Tu154M.

Specifications	ECN-319	ECN-323	ECN-325
Type of pump	Emergency booster	Transfer	Booster
Electric motor	DC	Induction	Induction
Voltage, V	27	200	200
Rated current A	< 15	< 2.6	< 8.3
Starting current	unknown	< 15.6	49.8
Pressure drop, kG/cm ²	1.6	0.45	1.25
Flow, l/h	1,500	2,000... 7,000	3,500... 12,000
Mass of pump, kg	3.8	4.0	5.8
Number of pumps	2	12	4

Fuel pumps of the Tu-154M are driven by 115/200 V AC induction motors and 27 V DC brush motors (Table 2.1). A flange mounted motor and pump constitute one integral unit (Fig. 2.12a). The feeding cables in fuel tanks are in aluminum tubes (Fig. 2.12b). Arcing in wiring system that delivers electric energy to fuel pump motors can theoretically ignite the *fuel-air mixture* in the wing tank [44, 32, 35, 37, 42].

In general, there are two types of fuel pumps on typical aircraft [35]:

- Fuel *transfer pumps* (e.g., ECN-323), which perform the task of transferring fuel between the aircraft fuel tanks to ensure that the engine fuel feed requirement is satisfied;

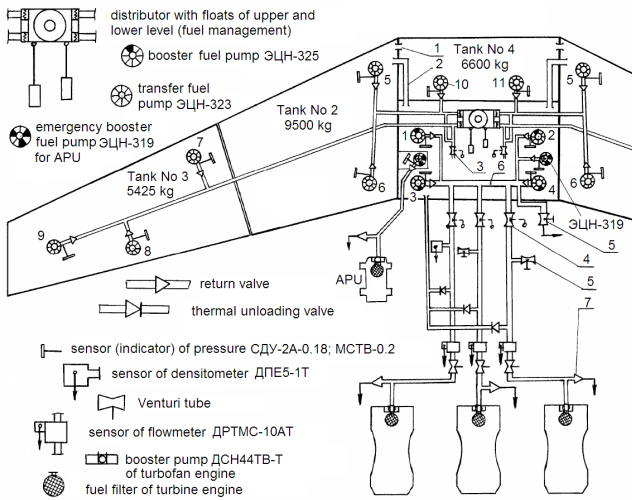

Figure 2.11: Tu154M fuel system layout. Fuel tanks, fuel pumps, fuel transfer lines, D-30KU engine and APU have been shown. 1,2 – feed lines of upper transfer from tanks No 4 and No 1 to tank No 2; 3 – faucet of reserve transfer; 4 – antifire faucet; 5 – discharge faucet, 6 – connector for maintenance of engines [50, 52, 54].

- Fuel booster pumps (e.g., ECN-325, ECN-319), also called engine feed pumps, which are used to boost the fuel flow from the aircraft fuel system to the engine.

Commercial aircraft use *open vent system* to connect the ullage¹⁰ space above the fuel in each tank to the outside air [35]. The Tu-154M is equipped with the vent system.

The Tu-154 uses fuel Jet A-1. Jet A-1 is a kerosene grade of fuel suitable for most aircraft turbine engines. It is produced to a stringent internationally agreed standard.

Fuel samples have not been collected from the crash site for testing by the Committee for Investigation of National Aviation Accidents (KBWL¹¹). KBWL tested fuel taken from the cistern UJ00204 at Warsaw Airport. Laboratory tests have confirmed that the fuel meets quality requirements (Raport Nr WK-2913-55-143-10). According to [29], fuel samples taken from the wreckage for tests by Russian Interstate Aviation Committee (MAK) has confirmed good quality of fuel.

According to [13], Section 4.10.3, the Tu-154M was fueled on April 7 (22 568 l) and April 9 (9518 l)¹². The airplane was not refueled on April 10, 2010.

¹⁰Space between the fuel surface and upper wall of the tank.

¹¹ In Polish „Komisja Badan Wypadkow Lotniczych Lotnictwa Cywilnego” (KBWLLC or KBWL).

¹² After return of D. Tusk from Prague.

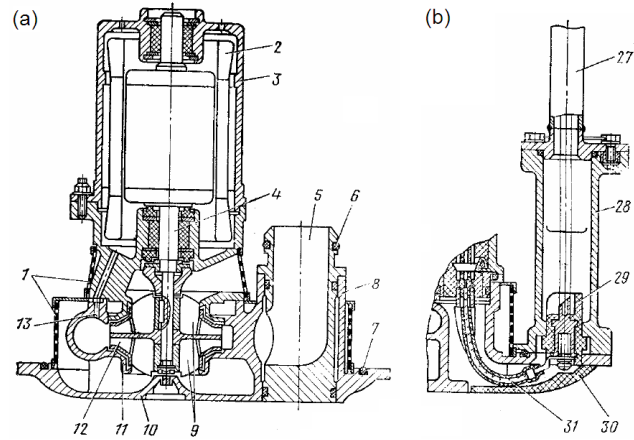

Figure 2.12: Booster fuel pump ECN-325: (a) cross section of fuel pump and induction motor; (b) electric wires. 1 – grid, 2 – induction motor, 3 – motor housing, 4 – shaft, 5 – tube, 6,7 – sealing rubber rings, 8 – pump housing, 9 – rotor, 10 – cover, 11 – snail, 12 – impeller, 13 – channel, 27 – conduit metal tube, 28 – tubing, 29 – terminal block, 30 – cover, 31 – electric cable. Construction of transfer fuel pump ECN-323 is similar [44, 50].

Assuming that fuel is equally distributed between the left and right wing tanks No 3, it should be from 650 to 725 kg of fuel in the left wing tank No 3 (Table 2.2) at the time of crash [15], Section 4.10.3. The surface of the bottom of the tank No 3 has been estimated approximately as 57 m². Assuming the specific mass density of Jet A-1 fuel as 800 kg/m³, the fuel level in the tank No 3 was from 14 to 16 mm. Such a thin layer of fuel on the bottom of a tank needs minimal heat input to the tank walls to reach the temperature exceeding the flash point and form combustible vapors in the ullage.

Table 2.2: Capacity of fuel tanks before and after crash

No of tank	Nominal capacity, kg	Last refueling, kg	After crash, kg
No 1 CWT (collector tank)	3,300	3,300	3,150 to 3,300
No 2 (two tanks)	2 x 9,500 = 19,000	4000	0
No 3 (two tanks)	2 x 5,425 = 10,850	5,372	1,300 to 1,450
No 4 (additional tank)	6,600	6,000	6,000
Total	39 750	1 8,672	10,450 to 10,750

Annexure No 4 [15], Section 4.5, p. 28/28 says that during *visual inspection of wreckage, no trace of detonation of explosive and fuel has been found*. Visual inspection cannot detect explosives. Detailed chemical examination and analysis of the wreckage must be done.

2.6 TU-154M WING ANTI-ICE SYSTEM AND ELECTRIC WIRING

Most civil aircraft use hot bleed air for anti-ice control of outer wing leading edges [35]. The Tu-154M must use electric resistive heating for anti-ice of the wing leading edge slats, as the turbofan engines are tail mounted and located far away from the wings. This would make the hot air bleed system very heavy and cumbersome.

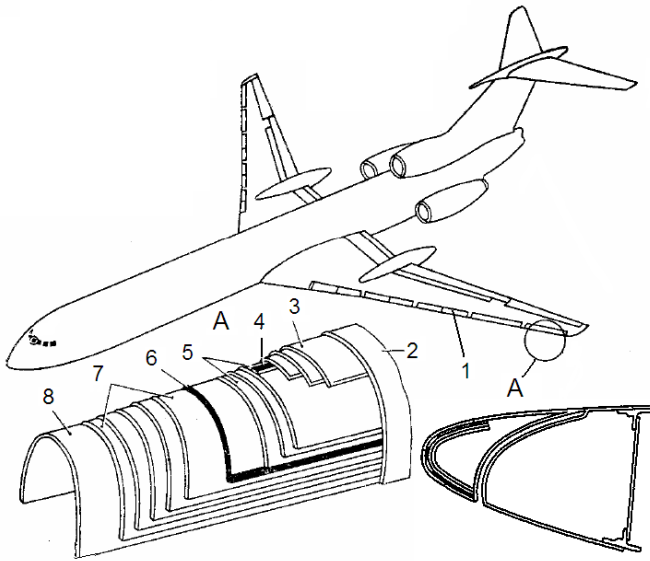

Figure 2.13: Leading edge wing anti-ice system: 1 – slat, 2 – outer skin/sheathing, 3, 5, 7 – thermal glass insulation, 4 – thermal “knife” (NiCr foil), 6 – heating element (composites), 8 – inner skin/sheathing [44, 52].

The Tu-154M has three-phase, 115-V electrical wing anti-ice heating system (Fig. 2.13) [44, 52]. To save electrical energy, heating elements are fed cyclically by adequate determination of time period. Under cyclic heating a thin layer of ice accumulates on slats which does not deteriorate aerodynamic properties of the aircraft. When the accumulation reaches a thickness threshold and the temperature of skin increases, the ice is taken out by the air stream.

The generator GT40PCh6 No 2 driven by the mid turbofan engine No 2 feeds only electric grid 2 (Fig. 1.5) dedicated to heating wing slats. The electric apparent power is 43.6 kVA at 115 V (phase) and ≤ 130 A.

Heating elements (composites) of one half of slats are divided into eight sections. The other half of slats has

also eight sections. Sections are fed in the following sequence: 1st, 2nd, ... 8th, 1st, 2nd, ... 8th Sections are numbered starting from the core part of the wing to the end of the wing. The current is on for 38.5 s and off for 269.5 s for each section.

In the leading part a thermal “knife” is installed along the slats. This part is made of 20-mm wide X20H80 NiCr foil. The thermal “knife” is not fed cyclically – it is steadily under current and is isolated from the outer skin by three layers of glass fiber 3 (Fig. 2.13). Also, the three layers 5 isolate the thermal “knife” from the heating element. On the inner skin/sheathing of heating element of the slat, thermal switches for cyclic operation of sections and thermal “knife” are installed. Thermal switches protect slats and heating elements against overheating.

2.7 ELECTRIC IGNITION OF AIRCRAFT FUEL

Characteristics of aviation turbine engine fuel Jet A-1 are given in Table 2.3. Jet A-1 is a *kerosene grade* of fuel suitable for most turbine engine aircraft. This is a *complex mixture of hydrocarbons* consisting of paraffins, cycloparaffins, aromatic and olefinic hydrocarbons predominantly with the C9 to C16 carbon numbers [27].

The *flash point* of the fuel is the minimum temperature at which sufficient vapor is released by the fuel to form a flammable vapor-air mixture near the surface of the liquid or within the vessel used [27]. For Jet A-1 fuel the flash point is 38°C (Table 2.3).

Table 2.3: Characteristics of fuel Jet A-1 [25]

Density at 15°C, kg/m ³	775 to 840
Flash point, °C	38
Auto-ignition temperature, °C	210
Freezing point, °C	– 47 (– 40 for Jet A)
Open air burning temperature, °C	260 to 315
Maximum burning temperature, °C	980
Minimum net heat of combustion (specific energy), MJ/kg	42.8
Electric conductivity, $\times 10^{-12}$ S/m	1.0 to 20.0
Gravimetric energy content, MJ/kg	43.5
Volumetric energy content, MJ/l	31.1

Flammability limits are experimentally determined upper and lower flammability boundaries of fuel concentration between which the fuel-air mixture only burns [3]. The upper (UFL) and lower (LFL) flammability limits in the air depend on initial temperature and pressure [3]. Thus, there is a limiting minimum and maximum *fuel-to-air* ratio. Below the LFL, the fuel-air mixture

Table 2.4: Hazard and causes of fuel ignition in tanks.

Hazard	Cause
In-tank electrical wiring	<ul style="list-style-type: none"> hot wires short circuit induced currents chemical damage mechanical damage
Fuel pump motor wiring	<ul style="list-style-type: none"> short circuit electric arcing
Electric motor of fuel pump	<ul style="list-style-type: none"> interturn short circuit phase-to-phase short circuit phase-to-housing short circuit
Pump dry-running (there are fuel lubricated bearings)	Sparks generated due to mechanical friction
Adjacent systems, e.g., electric anti-ice system	<ul style="list-style-type: none"> electric arcing external to the fuel tank heating of tank walls explosion within the adjacent area
Static electricity build-up (ECA) due to fuel circulation [33]	Electrical discharge (ESD) from fuel surface to tank walls
Lighting [11, 32]	<ul style="list-style-type: none"> ESD within the fuel tank electrical arcing between components (inadequate distance between components)

is too lean to burn. When UFL is exceeded, the vapor space mixture is too rich in fuel to be flammable. When considering only equilibrium conditions, the particular fuel-to-air ratio, which can exist is determined by the temperature and pressure of the system. The temperature determines the quantity of the fuel by controlling its vapor pressure, and the altitude determines the quantity of air. Therefore, by a suitable combination of temperature and altitude, under equilibrium conditions, the ullage of a fuel tank can be made either flammable or nonflammable [37].

As stated in Table 2.3, Jet A-1 fuel under static conditions and under 38°C is typically not flammable. Small amount of fuel in the tank forms a very thin liquid layer across the bottom surface and is more dangerous than full fuel tank. Any heat input into this fuel layer can rapidly raise its temperature to above the flash point

of the fuel, thus forming combustible vapors in the ullage. Table 2.4 lists sources and causes of fuel ignition (explosion) in the tanks.

There are many factors that determine how and how much this heat transfer affects the fuel tank temperature and the flammability of the ullage space. These factors include the operational environment, flight operations, condition of the aircraft, the amount and temperature of fuel loaded in the tank, and other variables. In many cases, the fuel temperature is sufficiently high that the fuel-air mass ratio in the ullage space is above the lower flammability limit (fuel/air > 0.03).

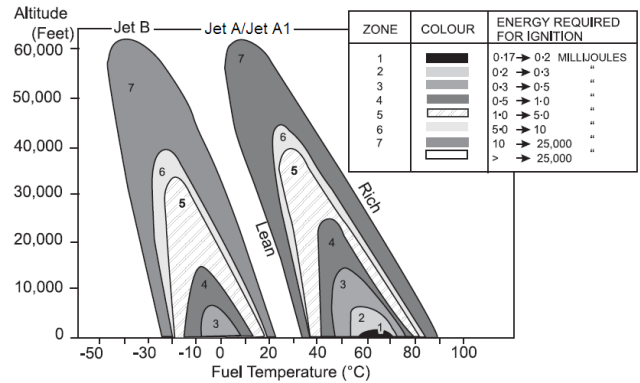

Figure 2.14: Flammability envelopes and estimated minimum electrical ignition energies for Jet A/Jet A-1 and Jet B fuels [27].

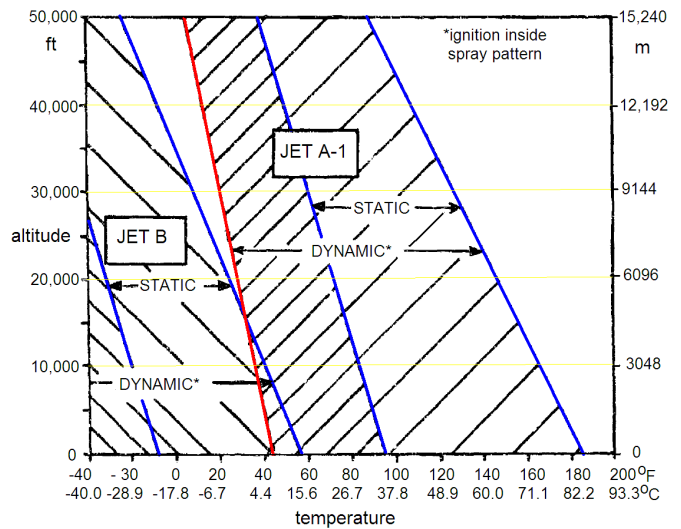

Figure 2.15: Static and dynamic flammability envelopes for Jet A-1 and Jet B fuels [37].

The *static electricity build-up* or *electrostatic charge accumulation* (ECA) is a dangerous hazard of fuel igni-

tion [33]. Electrostatic charge can develop due to fuel pumping, fuel splashing and fuel turbulence in the tank. The high electric potential between the surface of fuel and the metallic parts of tank can generate sparks, even though all structural parts of the tank are electrically connected together. This is called the *electrostatic discharge* (ESD) as a result of ECA. Pure hydrocarbons are essentially nonconductors. Kerosenes may have electric conductivity ranging from less than 1.0×10^{-12} S/m to 20.0×10^{-12} S/m at 20°C. For comparison, the conductivity of deionized water is about 10.0×10^{-6} S/m [25]. The higher the conductivity of fuel, the lower the probability of sparks due to static electricity build-up. Military jet fuels and international Jet A-1 fuel require the use of additives that increase the electric conductivity of fuel [25].

The environmental parameters of temperature and altitude which affect the flammability of the tank ullage, are illustrated by the so called *flammability envelope*. Traditional flammability envelopes have been available for many years [27]. The envelopes shown in Fig. 2.14 together with ignition energies, were derived by British Aerospace in the 1970's [27]. It should be noted that the flammability limits are not specification requirements, which include instead flash point, vapor pressure, and distillation of the particular fuel type.

Under dynamic conditions (pressure and temperature transient), the flammability envelope extends towards lower temperatures, as shown in Fig. 2.15 [37]. The dynamic flammability envelope for Jet A-1 fuel shows, that the flash point at low altitudes is as low as 4 to 5°C.

Auto-ignition or *ignition temperature* (Table 2.3) is the temperature at which the material will ignite on its own without any outside source of ignition.

2.8 DESIGN OF FUEL TANKS

Since the introduction of kerosene fuel for civil aircraft use in the late 1940's, the aircraft designers have been aware that the ullage would contain a mixture of fuel vapor, or mist and air, which could be ignited in the presence of a spark, flame, or hot surface.

To prevent tank explosions, designers have always assumed a flammable vapor exists in the fuel tanks and adopted standards to preclude ignition sources from the fuel tanks. The following are some of the design measures taken to satisfy that philosophy [27]:

A. Surface temperatures inside the tanks, under normal and failure conditions, are kept at least 10°C below the minimum necessary to ignite a fuel-air mixture. Pump motors are kept cool by an integral passage of circulating fuel. The motors have a temperature fuse, which cuts the electrical supply before an unsafe surface temperature is reached. In addition, the pumps and

other similar equipment inside the tanks, are designed and tested to explosion-proof standards. Bleed air pipes or *electric heating elements in the wing leading edge are frequently routed close to fuel tank walls*. In such a case, heat-sensitive detector wires are installed to protect fuel tanks from overheat.

B. Electrical components and wiring within a fuel tank are designed to handle 1500 V AC which is well in excess of the voltage available on the airplane.

C. Electrical energy applied to any component in the fuel tank is limited to a value that is 10 times lower than the minimum energy necessary to ignite a fuel-air mixture. The *minimum ignition energy* (MIE) for hydrocarbon vapors is about 0.25 mJ.

D. During the flow of a *hydrocarbon type fuel* through pipes, valves, filters, etc., an *electrostatic charge* can be generated in the fuel, which, if relaxed sufficiently fast, could allow the accumulation of hazardous potential levels inside a receiving tank. Therefore, it is necessary to avoid very high rates of fuel flow in the refueling system and control distribution of the fuel in the tanks (bottom loading and the use of diffusers on pipe outlets). In addition, meticulous attention is paid to electrical connection of all metallic parts to dissipate the charge. The use of special additives in the fuels to increase the fuel electrical conductivity is required in some countries.

A major consideration of fuel system safety is protection against the effects of lightning [11, 27, 32]. When an aircraft is struck by lightning, a pulse of high current flows through the aircraft from the entrance to the exit points. Protection against this phenomenon is provided in a number of ways (well bonded structure of aircraft, thick wing skin panels, proper location of tank vents, etc.).

2.9 WHAT COULD HAPPEN TO THE LEFT WING?

Only detailed investigation of the wreckage can answer the question what really happened to the left wing of the Tu-154M No 101. So far, the wreckage is not available to independent investigators and only photographs taken at the crash site and wreckage storage site can be examined.

Careful examination of the crash site and description of debris immediately after crash could help to prove the hypothesis of fuel explosion. For example, a fuel pump (installed inside a fuel tank), if found in the debris field, would be a strong evidence of a fuel tank explosion.

The fuel tank No 3 was nearly empty, i.e., the thickness of the estimated fuel layer was from 14 to 16 mm spread over large surface of the tank (estimated surface of tank bottom about 57 m²). The partially empty fuel tank is more dangerous than the full tank as the ullage

for the formation of flammable vapors is larger. The explosion in the left wing tank No 3 could be a result of:

- (a) ignition due to short circuit and arcing inside the tank No 3;
- (b) fuel ignition due to static electricity build-up also called electrostatic charge accumulation (ECA);
- (c) explosion within the adjacent area of the left wing tank No 3.

Malfunction of anti-ice electric heating system installed in slats (Fig. 2.13) could lead to local temperature rise in the tank wall and create friendly conditions for fuel ignition by sparks or arcing. Fuel vapor *auto-ignition* due to local hot spot in fuel tank, or temperature rise due to malfunction of anti-ice electric system or other electrical equipment/wiring is rather impossible, since the auto-ignition temperature of Jet A-1 fuel is 210°C (Table 2.3). More realistic is *electrostatic charge build-up* (ECA) due to fuel flow and hazardous electric potential level inside the tank.

Explosion within the adjacent area due to other than electrical causes is very likely to happen [45].

There is also enigmatic statement in Annexure No 4 [15], Section 4.10.3, p. 3/5: *At 05:59:005 UTC the flight recorders received a signal of failure or manual disconnection of control and measurement of fuel consumption system SUIT4-1T. . . . The flight technician should immediately report all deviations in the fuel system to the aircraft commander. The cockpit voice recorder (CVR) does not show any evidence of such a report. It can be presumed that reconnection of control and measurement of fuel consumption system into manual mode was intentional. . . . However, the real cause of the reconnection of the control and measurement of fuel consumption system into manual steering mode remains unknown in this flight.*

2.10 CONCLUSIONS

Although probability of explosion of fuel-air mixture in the left wing outer tank No 3 due the static electricity, electric short circuit or arcing is low, this problem cannot be neglected in further investigation of the accident, especially examination of the wreckage, its remaining electrical equipment and left wing fuel tank No 3. Careful attention should be given to fuel pumps, electric motors for fuel pumps, electric anti-ice system of slats, all power cables/wires in fuel tank No 3 and in its vicinity.

The hypothesis of the second explosion in fuselage [45] could theoretically also be caused by explosion of fuel in the CWT.

Part 3:

FULL-SCALE CRASH DYNAMIC TESTS OF DC-7 AND LC-1649 VERSUS HYPOTHETICAL COLLISION OF TU-154M WITH BIRCH TREE

3.1 INTRODUCTION

In 1964 full-scale dynamic crash tests on the DC-7 and Lockheed 1649 Constellation have been performed by the Federal Aviation Agency, USA, Aviation Safety Engineering and Research, USA, and number of other agencies and organizations [40, 41]. The objective of these experiments was *exploration of the manner in which large aircraft are damaged in survivable accidents and accurate measurement of the crash loads* [40, 41]. In the case of the DC-7, after collision with telephone poles, the tip of right wing finally fell off [17, 40]. This fact is frequently cited by supporters of the Tu-154M No 101 crash official reports [13, 29] as a proof that the collision of the Tu-154M No 101 with the trunk of a birch tree on April 10, 2010 near Smolensk North Military Air Base severed the tip of the left wing and finally caused fatal collision of the Tu-154M No 101 with the ground.

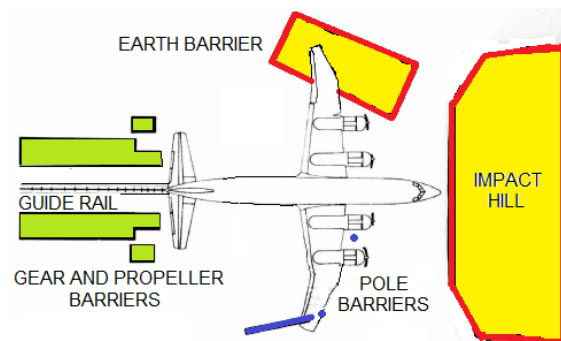

Figure 3.1: DC-7 test site and wing impact sequence. Telephone poles have been marked with blue color [40].

It is necessary to point out the following differences in:

- weight and volume envelope of the Tu-154M, DC-7 and LC-1649 aircraft;



Figure 3.2: LC-1649 full-scale dynamic crash test. Out-board pole impact [41].



Figure 3.3: LC-1649 full-scale dynamic crash test. In-board pole impact [41].

- construction of aircraft and their wings;
- kinetic energy of aircraft;
- height at which the wing hit the pole or tree;
- properties of timber/wood;
- how the telephone poles and birch tree have been anchored.

3.2 TEST SITE

The test site has been designed in such a way as to obtain the desired impact conditions for accelerating the test aircraft to approximately the climbout velocity, controlled guidance of the aircraft to the initial impact point, and appropriate location of earthen barriers and telephone poles (Fig. 3.1).

The runway consisted of two soil-cement strips 4.57-m wide and 5.49-m apart laid over the desert soil to support the main landing gear wheels [40, 41]. The length of strips from release point to the impact barriers was 1219 m [40, 41]. The aircraft was guided along a single track made of standard 41-kg railroad rails laid on a continuous reinforced concrete base [40, 41].

The rock, earthen and pole barriers were erected to break the nose landing gear, propellers of engines and

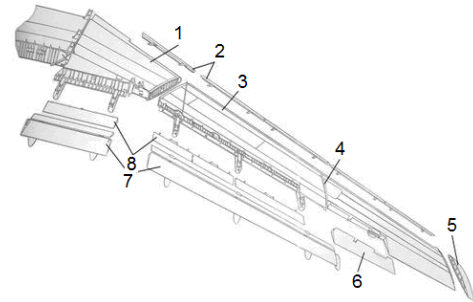

Figure 3.4: Construction of wing of Tu-154. 1 – center section, 2 – slats, 3 – detachable portion of the wing, 4 – wind baffle, 5 – limit fairing, 6 – aileron, 7 – flaps, 8 – spoilers [52].

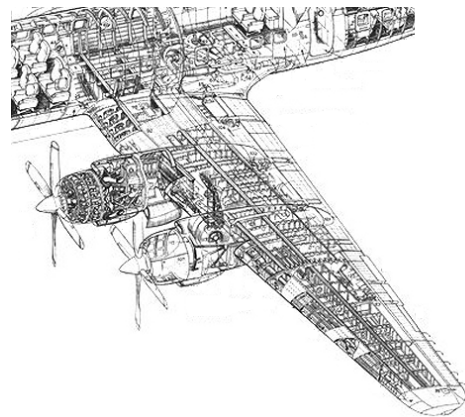

Figure 3.5: DC-7 wing cutaway. Source: www.flightglobal.com

wings, respectively [40, 41]. The left wing earthen barrier was a 4.57-m high inclined earthen mound with the face sloped 35° (Fig. 3.1). The right wing pole barriers (Figs 3.2 and 3.3) were made of standard 0.305-m diameter telephone poles (southern yellow pine) buried approximately 1.22 m in the ground [40, 41]. The earthen impact hill located behind the wing barriers (Fig. 3.1) was an 8° slope extending for approximately 38 m along the main axis of the test site [40, 41].

In the presented comparative analysis of the Tu-154M, DC-7 and LC-1649 only the wing pole barriers have been discussed (Figs 3.2 and 3.3). Conditions prior to crash or full-scale dynamic tests are summarized in Table 3.1 [22].

3.3 CONSTRUCTION OF AIRCRAFT

The Douglas DC-7 military transport and civilian aircraft were built by the Douglas Aircraft Company, Santa Monica, CA from 1953 to 1958.

Table 3.1: Conditions prior to crash or full-scale tests.

Parameter	Tu-154M 101	DC-7	LC-1649
Gross weight of airliner at the time of crash/test, kg	78,600 (estimated [13])	49,010 [40]	72,245 [41]
Velocity prior to contact with barrier, km/h	approx. 260.0 (birch tree)	257.4 (landing gear barrier)	207.6 (landing gear barrier)
Linear momentum, MNs	5.896	3.504	4.166
Kinetic energy, MJ	221.1	125.3	120.1
Leading edge sweep of wings, degree	approx. 37	approx. 5	approx. 6
Material of wooden barriers	birch tree	processed pine	processed pine
Height of impact point measured from the ground level, m	approx. 6.6 [7, 9]	approx. 3.2	approx. 2.0
Diameter of pole/tree, m	approx. 0.4 [7, 9]	0.305	0.305
Distance of impact point measured from the center axis of the fuselage, m	12.675	13.83	unknown
Length of the tip wing being cut off, m	6.1	3.66	unknown

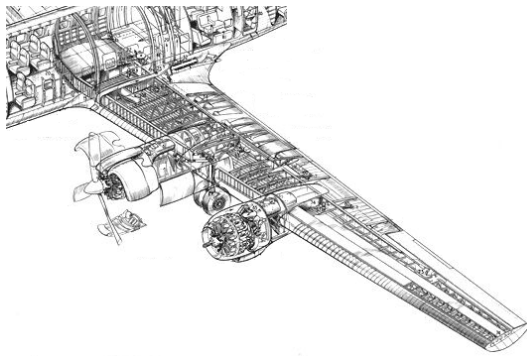

Figure 3.6: LC-1649 wing cutaway. Source: www.flightglobal.com

The Lockheed Constellation model 1649 aircraft was built by Lockheed, Burbank, CA between 1943 and 1958. A total of 856 aircraft were produced in various models. The Constellation was used as a civilian airliner and as the US military transport plane, servicing amongst other the *Berlin Airlift*. It was the presidential aircraft for the US President D. D. Eisenhower.

The first version of the Tu-154M project appeared in 1964 [31]. A pair of Tu-154M "Salons" (VIP version "Lux") was delivered to Polish Air Force in June 1990, reserialled "01" and "02" in 1995 [31].

The Tu-154M is propelled by three D30-KU turbofan engines, while the DC-7 and LC-1649 are propelled by four R3350 piston engines. The Tu-154 has rear-engine layout with its wings "aerodynamically clean". The DC-7 and LC-1649 have engines buried in the wings.

The construction of wing of the Tu-154 is shown in Fig. 3.4. The 3D cutaways of DC-7 and LC-1649 wings with engines are shown in Figs. 3.5 and 3.6.

Specifications of the Tu-154M, Douglas DC-7 and Lockheed Constellation LC- 1649 are listed in Table 3.2. Dimensions of all three aircraft are sketched in Figs 3.7 and 3.8. The Tu-154M is much longer (47.9 m versus 29.53 m and 35.41 m) and heavier (empty weight 55.3 t versus 37.785 t and 41.969 t) aircraft than the DC-7 and LC-1649.

The *leading edge sweep*¹³ of the wing (Fig. 3.9) is about 37° for the Tu-154M, about 5° for the DC-7 and about 6° for the LC-1649 aircraft (Table 3.1). It is easier to cut a pole/tree barrier by a wing with large leading edge sweep angle (Tu-154M) than by a wing almost perpendicular to the center line of the fuselage (DC-7, LC-1649). For example, to decrease the amount of force required in a guillotine cutter and to cut the material more swiftly, the blade is angled [22]. This angle is referred to as the *shear angle* or the *rake angle of a shear*¹⁴. The shear angle decreases the force, but increases the stroke [26].

3.4 DYNAMIC TEST RESULTS

In the case of dynamic tests of the DC-7, the impact of the right wing with the outboard pole cut off the wing approximately 3.66 m from the tip [40]. Roughly 0.15 s after the first pole impact, the aircraft contacted

¹³ The leading edge sweep is the angle between a constant percentage chord line along the semispan of the wing and the lateral axis perpendicular to the aircraft center line.

¹⁴The rake angle of a shear is the slope of the upper blade of a guillotine cutter from the left to the right.

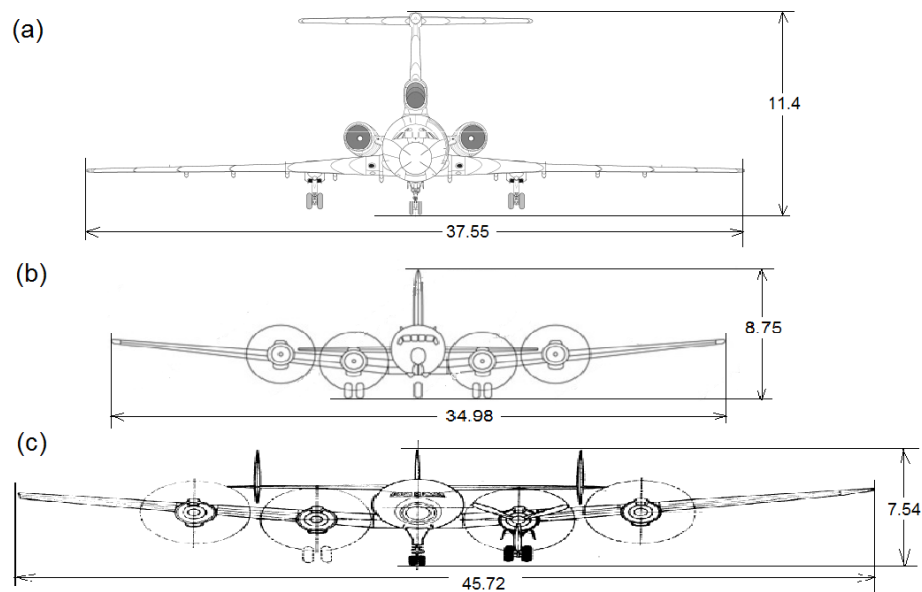

Figure 3.7: Comparison of wing span: (a) Tu-154M; (b) DC-7; LC-1649.

the second pole barrier, which crushed the wing leading edge structure back to the forward spar [41]. Then, the second pole broke [40]. The left wing tip after touching the earthen wing barrier suffered only a slight flattening [40].

The left wing of the LC-1649 after striking the earthen barrier separated from the fuselage at the wing root [41]. The right wing hit the pole barriers, which opened up the wing about 7.6 m from the tip and between engines [41]. At approximately the same time, the fuselage touched the ground and finally became separated from this right wing section [41].

According to [17], in the case of the DC-7 the wing tip detachment process was due to air resistance at a distance of about 20 m behind the point of impact (pole). The wing tip of the DC-7 was torn off in a more distant place from the fuselage than the point of impact with the pole. The wing tip of the LC-1649 fell off only when the aircraft hit the ground [4, 5, 17, 41].

3.4.1 DC-7 release and crash sequence The DC-7 aircraft was released for full-scale dynamic test under the following arrangements [40]:

- Normal take-off configuration;
- Flaps positioned full-up to reduce lift and drag;

- Upon release, the throttles advanced to pre-determined take-off position, 3050 bhp¹⁵ (2.275 MW) per engine;
- Smooth and continuous acceleration of the aircraft during the 1292 m run until the impact with the propeller and landing gear barriers (Fig. 3.10);
- Velocity of 257.4 km/h (139 knots).

The step-by-step crash test sequence of the DC-7 is described below [40]:

- The first barrier was the landing gear barrier (Fig. 3.10a).
- All four propellers were broken as a result of hitting the propeller barriers (Fig. 3.13b). All four engine mounts failed.
- The gear barrier torn out the right main landing gear, which struck the right horizontal stabilizer (Fig. 3.10c).
- The impact with the outer pole (Fig. 3.1) cut off the right wing approximately 3.66 m (12 feet) from the tip. The main tank No 4 (Fig. 3.11) was ruptured by the pole.

¹⁵ Brake horsepower (bhp) is measured with a dynamometer (brake), which measures the true power of the engine, without power losses caused by the gearbox, generator, pumps, and other auxiliary equipment.

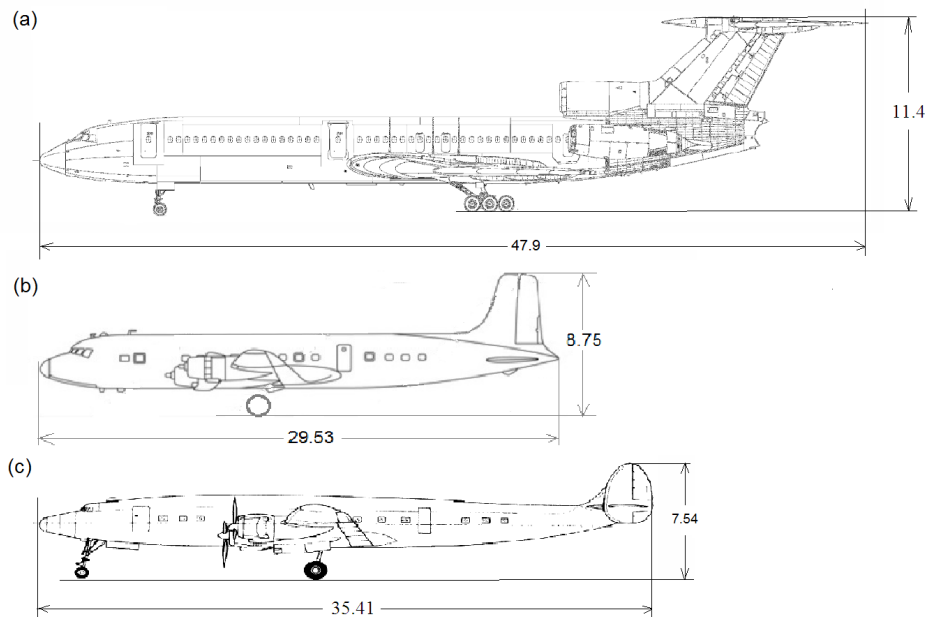

Figure 3.8: Comparison of length of aircraft: (a) Tu-154M; (b) DC-7; (c) LC-1649.

- The aircraft hit the second inner pole approximately 0.15 s after the first pole impact. The inner pole struck the right wing between engines No 3 and No 4 (Fig. 3.11). The wing leading edge structure back to the forward spar was crushed. Then, the inner pole broke.
 - The left wing tip rasped the earthen wing barrier, experiencing only slight flattening underneath its tip.
 - The aircraft struck the 8° impact hill after passing through the poles. While sliding up the hill, both wings failed at the wing roots and the fuselage broke.
 - The aircraft slid along the 8° slope of the impact hill and then struck the 20° slope approximately 3.0 m (10 feet), vertically from the summit.
 - The final impact occurred on the back side, at the foot of the hill. The main portion of the aircraft came to rest 262 m (860 feet) from the point of initial collision with the main landing gear barriers.
 - During passing over the summit of the hill, the left wing, torn completely free, flew ahead of the fuselage and impacted approximately 15.2 m (50 feet) ahead of the main fuselage.
 - The right wing remained fastened to the fuselage by the control wires and came to rest right side up.
 - The aft section of the fuselage came to rest at a 45° angle to the flight path and rolled over on its left side.
 - The tail section of the aircraft broke partially free of the main fuselage.
- Most of large pieces remained together during the entire sequence of test and came to rest in a small area on the center line of the original path. A lot of smaller parts were scattered over the crash site. Several small fires occurred when the aircraft broke up during the test [40].
- Prior to the initial impact with the landing gear barriers, a voltage control regulator failed in the on board data recording system resulting in the loss of all electronic data in the airborne recording system [40].

3.4.2 LC-1649 release and crash sequence

The LC-1649 aircraft was prepared for full-scale dynamic test as follows [41]:

- Normal take-off configuration;
- Flaps positioned full up to reduce lift and drag;
- Upon release, the throttles were moved to the pre-determined power settings;
- Smooth acceleration along the guide rail until the impact with the propeller and landing gear barriers;
- Velocity of 207.4 km/h (112 knots).

Table 3.2: Specifications of Tu-154M, Douglas DC-7 and Lockheed Constellation 1649 aircraft

Specifications	Aircraft		
	Tu154M	DC-7	Lockheed Constellation Model 1649
Dimensions:			
Wing span , m	37.55	34.98	45.72
Length, m	47.90	29.53	35.41
Height, m	11.40	8.75	7.54
Wing area, m ²	201.5	188.3	171.87
Weights			
Empty weight, kg	55,300	37,785	41,969
Loaded weight, kg	max 100,000	57,200	72,575
Performance			
Max. speed, km/h	950	650	606 at 5669 m
Cruising speed, km/h		560	466
Service ceiling, m	11,100	6850	7223
Max range, km	5200	9000	9945 with 3628 kg payload
Range with max payload, km	3900	7400	7950 with 8845 kg payload
Power plant	Three Aviadvigatel (Soloviev) turbofan D-30KU rated at 108 kN (24,270 lb) each	Four Wright R-3350 turbo compound radial rated at 2420 kW (3250 hp)	Four Wright Cyclone R-3350-988TC-18EA-2 turbo compound rated at 2535 kW (3400 hp) each

The step-by-step crash test sequence of the LC-1649 is outlined below [41]:

- The left landing gear was broken (Fig. 3.10) and caused the engine No 2 (Fig. 3.12) to roll under the left wing.
- The right landing gear was also broken and severed the right vertical fin of the right horizontal stabilizer.
- The propeller of the engine No 2 (Fig. 3.12) was sheared off by the landing gear barrier.
- The engines No 1, 3, and 4 (Fig. 3.12) and their propellers were intact, with the exception of one propeller blade of the engine No 3, which was sheared off by the right main gear barrier (Fig. 3.10).
- The rail guide shoe was broken off on impact with the nose gear barrier (Fig. 3.10c). The gear strut was forced into the forward fuselage.
- After passing through the gear barriers and hitting the earth, propellers on engines No 1, 3, and 4 (Fig. 3.12) lost their blades. A tear in the wing structure adjacent to the engine nacelles became visible.
- The left wing struck the earthen barrier and started to separate from the fuselage at the wing root, while the right wing hit the poles.
- The first pole nearly sheared off the outer panel of the right wing and opened up the fuel tank No 4 (Fig. 3.12) about 7.6 m (25 feet) from the tip (Fig. 3.2). The second pole cut into the wing and the No 3 fuel tank between the engines No 3 and No 4 (Fig. 3.12). The portion of the right wing inboard of the No 3 engine nacelle remained attached to the fuselage throughout the crash (Fig. 3.3).
- The fuselage contacted the ground at approximately the same time and as it slid along this partially severed right wing section, finally became separated, and came to rest upside down.
- The nose of the plane contacted the ground at the threshold of the 6° slope and climbed into the impact hill. No major breakup of fuselage structure occurred during this impact.

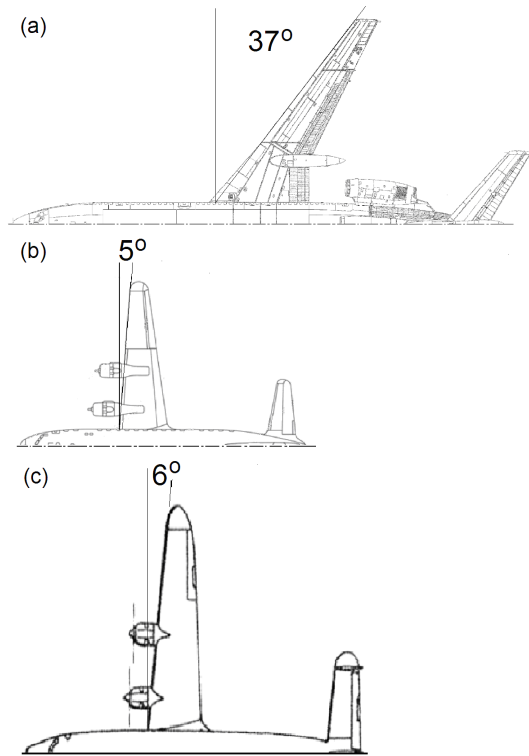

Figure 3.9: Leading edge sweep of wings of (a) Tu-154M, (b) DC-7 and (c) LC-1649 aircraft.

- The impact with the 20° degree slope broke the aft of the cockpit and aft of the galley.

The main landing gear, right vertical stabilizer and all major parts of the aircraft except for the engines came to rest in a small area with the fuselage nearly aligned with the line of the guide rail. Small fires resulted as the aircraft broke up during the crash [41].

3.5 COLLISION OF TU-154M WITH BIRCH TREE

There is no clear evidence that the Tu-154M Nr 101 on April 10, 2010 hit the trunk of a *birch tree* situated 63 m to the left of the glide path and 855 m from the RWY26 runway threshold. According to K. Nowaczyk [39], the data retrieved in the US by Universal Avionics Systems Corporation [28] show that the Tu-154M has been destroyed at an altitude of about 20 m above the crash site level. These records have been known to the Committee for Investigation of National Aviation Accidents (in Polish KBWL) [13], but have not been disclosed [39].

The “armoured” birch tree has appeared in Polish media two weeks after the crash. Before that, it was officially claimed that the wing of the plane hit the mast

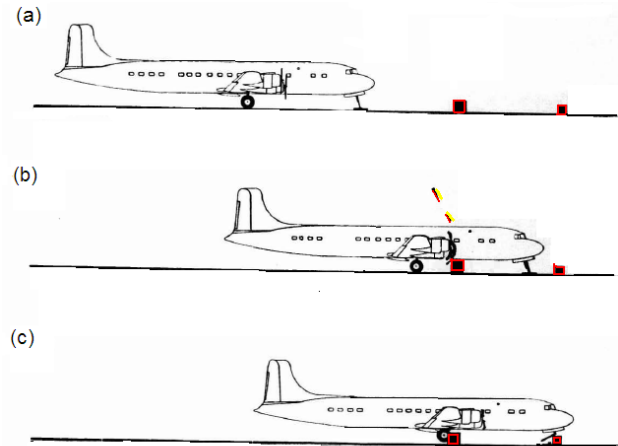

Figure 3.10: Gear and propeller impact sequence: (a) aircraft approaching gear and propeller barriers; (b) impact with propeller barrier; (c) impact with main and nose landing gear barrier [40].

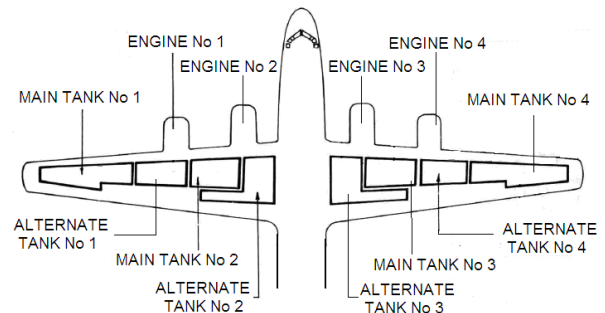

Figure 3.11: DC-7 fuel tank and engine locations [40].

of the inner non-directional radio beacon (NDB) located 1100 m away from the runway threshold.

There is also no evidence of detailed investigation of the birch tree and separated tip of the left wing. The photograph taken immediately after the crash (Fig. 3.13) does not show any pieces of metal embedded in the wood. The photographs taken by S. Amelin also do not show chunks of metal. Recently, the part of the trunk with fracture has been cut off (Fig. 3.15).

The tip of the severed wing looks peculiar (Fig. 3.15). The slat has not been damaged and protrudes several inches beyond the cut-off line of the wing. Slat of the left wing have been almost intact along the entire length, only with three small cavities. The report [13] does not explain why the adjacent slat, extending in the direction of the fuselage had not been destroyed by the hypothetical collision with the trunk of a birch tree, and how did it happen that the zone of destruction begins behind the slat (Fig. 3.15).

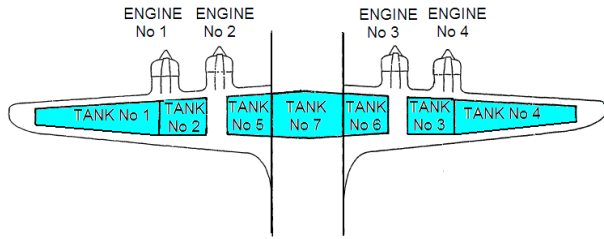

Figure 3.12: LC-1649 fuel tank and engine locations [41].



Figure 3.13: Fracture of the trunk of birch tree situated 855 m from the RWY26 runway threshold and 63 m to the left of the glide path. No piece of metal is visible. Photograph taken immediately after crash.

3.6 CONCLUSIONS

From the presented comparative analysis the following conclusions can be drawn:

(a) The Tu-154M is much longer (47.9 m versus 29.53 m and 35.41 m) and heavier (empty weight 55.3 t versus 37.785 t and 41.969 t) aircraft than the DC-7 and LC-1649, respectively.

(b) The construction of the Tu-154M, DC-7 and LC-1649 aircraft and their wings is very different, e.g., leading edge sweep (Fig. 3.15). The first version of the Tu-154M was designed in 1964, while the DC-7 was designed before 1953 and LC-1649 before 1943. The rear turbofan engines of the Tu-154M are mounted in the tail. The reciprocating engines of the DC-7 and LC-1649 are buried in wings.

(c) The kinetic energy prior to impact of the Tu-154M was 221.1 MJ versus 125.3 MJ for the DC-7 and 120.1 MJ for the LC-1649.

(d) It is easier to cut a pole/tree barrier by a wing with large sweep angle (Tu-154M) than by a wing with its leading edge almost perpendicular to the center line of the fuselage (DC-7, LC-1649).



Figure 3.14: The part with fracture of the birch trunk was cut off probably in September 2012. Photograph uploaded on November 14, 2012. Source: <http://imgsrc.ru/para-moto1/30127119.html>.

(e) The physical parameters of the “live” birch tree are different than those of telephone poles made of processed timber (processed southern yellow pine).

(f) The height of impact point measured from the ground level is different for each case, i.e., approximately 6.6 m for the Tu-154M, approximately 3.2 m for the DC-7 and approximately 2.0 m for the LC-1649.

(g) The birch tree grew probably in a meadow or swampy ground, while the telephone poles were buried approximately 1.22 m in the ground. It is unknown if a layer of concrete has been applied.

(h) Research performed by W.K. Binienda [1, 2] and K. Nowaczyk [38, 39], photographs of the birch taken immediately after the crash (Fig. 3.10), appearance of trees broken by wind gusts, lack of damage to the slat (Fig. 3.15) and lack of detailed investigation of the birch tree and wing testify that there was rather no collision of the Tu-154M No 101 with the trunk of a birch tree.

Therefore, the separation of the tip of wings in full-scale dynamic tests [40, 41] using the DC-7 and LC-1649 aircraft can not be a proof of cutting off the tip of the wing of the Tu-154M as a result of a collision with a birch tree trunk.



Figure 3.15: Tip of the left wing of the Tu154M No 101 after air crash. The main body of the wing has been cut off while the slat is intact.

<http://vfl.ru/fotos/aa582e8c473661.html>

GENERAL SUMMARY

The electric system of the Tu-154M aircraft is an outdated system typical for aircraft being designed in the 1960s. Reversed design and analysis of GT40PCh6 main synchronous generators deliver important information on steady-state and transient performance of these machines. Transient characteristics, especially short-circuit waveforms are very helpful in investigation of electric power system after crash. Credibility of flight parameters for electrical equipment and installation (Fig. 1.15) is questionable. There is not enough information how the recorded parameters have been secured, extracted and analyzed [13, 15]. It is now very difficult to find out if the electric power system was operating correctly in the last seconds of crash or not. According to [13, 15], the flight management system (FMS) lost electric power (memory freezing) at 10:41:05, i.e., at the time of collision with ground. Table 1.3 show standard procedure for examination of electrical equipment and installation after crash [18, 53]. The electrical equipment and wiring at the crash site was only inspected visually [13, 15]. There is still possible to examine synchronous generators and induction motors for fuel pumps and for other on-board equipment, e.g., air conditioning system provided that independent investigators will have access to the wreckage.

It is unlikely that the Tu-154M No 10 was smashed into small pieces scattered over large area (Fig. 2.1) as a result of mechanical impact to ground.

A collision of the Tu-154M with the birch tree could not cut off the tip of its left wing. Computer simulations using the LS-Dyna 3D FEM software [24] performed by W. K. Binienda show that independent of the angle of attack, trunk diameter and physical properties of the birch tree, the wing always cuts the trunk of the birch tree [1, 2]. The tip of the wing was severed rather due to explosion inside the wing [45]. Although probability of explosion of fuel in the left wing tank due to the static electricity, electric short circuit or arcing is low, this problem cannot be neglected in further investigation of the accident, especially in the examination of the wreckage.

The full-scale dynamic crash tests on the DC-7 and LC 1649 performed by the FAA, USA [40, 41] cannot be compared with the hypothetical collision of the Tu-154M No 101 with birch tree due to the following differences in (a) the weight and volume envelope of the Tu-154M, DC-7 and LC-1649 aircraft, (b) construction of aircraft and their wings, (c) kinetic energy of aircraft, (d) height at which the wing hit the pole or tree, (e) properties of timber/wood and other reasons. Also, recent full-scale experiment with a 170-seat Boeing 727 passenger aircraft (the Tu-154M is very similar to the Boeing 727) in Sonoran Desert, Mexico, has shown no fragmentation into small pieces when the aircraft hit the ground (Fig. 2.7) [47]. The fuselage torn only in two pieces (Fig. 2.7) [47] after hitting the ground with the speed of 225 km/h.

ACKNOWLEDGEMENTS

The author would like to thank Professor Chris J. Cieszewski of the University of Georgia, Athens, GA for his guidelines and kind assistance in preparation of the manuscript. Many thanks are due to the nine anonymous reviewers who provided valuable comments and constructive criticism of this work.

DISCLAIMER

Although all precautions have been taken and all findings are documented by appropriate references, the analyzed scenario and cause of crash, unless confirmed by detailed investigation of the wreckage, is only a hypothesis.

REFERENCES

- [1] Binienda, W.K. 2011. Dynamic analysis of the Polish governmental plane crash in Smolensk, Russia, on April 10, 2010. University of

- Akron, last updated November 25, 2011, <http://www.ecgf.uakron.edu/civil/people/binienda/Parlament%20November%202011%20-%20English.pdf>
- [2] Binienda, W.K. 2012. Analysis of destruction of the Polish governmental aircraft Tu-154M in Smolensk on April 10, 2010 (in Polish). Smolensk Conference, Warsaw, http://obserwator.com/files/files/Smolensk_Conference2012_WKB_polski_short.pdf
- [3] Bjerketvedt, D., J.R. Bakke, van Wingerden, K. 1993. Gas explosion handbook, electronic book, Christian Michelsen Research. 221 pages. <http://www.gexcon.com/handbook/GEXHBcontents.htm>
- [4] Bocchieri, R. T., MacNeill, R., Navarro-Northrup C., Dierdorf, D.S. 2010. Crash Simulation of Transport Aircraft for Predicting Fuel Release, FAA Worldwide Techn. Transfer Conf. Atlantic City, NJ.
- [5] Bocchieri, R.T., MacNeill, R.M., Northrup, C.N. 2012. Dierdorf, D.S. 2012. First phase-simulation of the Lockheed Constellation model L-1649 full-scale crash test, Report DOT/FAA/TC-12/43, U.S. Department of Transportation, FAA, Atlantic City, NJ.
- [6] Britton, S.C.G. 2010. Little Rock Air Force Base, Photograph No 100716-F-7087B-031.jpg posted August 8, 2010, <http://www.littlerock.af.mil/shared/media/photo/db/photos/100716-F-7087B-031.jpg>
- [7] Cieszewski, C.J. 2012. Assessment of wood properties for the birch samples from Poland, USA, and Smolensk using NIR spectroscopy and SilviScan, Smolensk Conference, Warsaw.
- [8] Cieszewski, C.J. 2012. Micro-detail comparative forest site analysis using high-resolution satellite imagery, Smolensk Conference, Warsaw.
- [9] Cieszewski, C.J., F. Antony, P. Bettinger, J. Dahlen, R.C. Lowe, M. Strub. 2013. Wood quality assessment of tree trunk from the tree branch sample and auxiliary data based on NIR Spectroscopy and SilviScan. *Math. Comput. For. Nat.-Res. Sci. (MCFNS)*, 5(1): 86–111. Last accessed online on Mar. 30, 2013, at: <http://mcfns.com>.
- [10] Cieszewski, C.J., R.C. Lowe, P. Bettinger, A. Kumar. 2013. Micro-detail comparative forest site analysis using high-resolution satellite imagery. *Math. Comput. For. Nat.-Res. Sci. (MCFNS)*, 5(1):16–37. Last accessed online on Mar. 30, 2013, at: <http://mcfns.com>.
- [11] Clifford, D.W. 1980. Aircraft mishap experience from atmospheric electricity hazards, atmospheric electricity-aircraft interaction. NATO AGARD-LS-110, National Technical Information Service, Springfield, VA, 22161.
- [12] Collision With Trees on Final Approach Federal Express Flight 1478 Boeing 727-232F, N497FE, Tallahassee, Florida, July 26, 2002, NTSB, Report NTSB/AAR-04/02, PB2004-910402, Washington DC. 2004.
- [13] Committee for Investigation of National Aviation Accidents KBWL. 2011. Final Report on the examination of the aviation accident no 192/2010/11 involving the Tu-154M airplane, tail number 101, which occurred on April 10th, 2010 in the area of the Smolensk North airfield, Warsaw (In Polish).
- [14] Committee for Investigation of National Aviation Accidents KBWL. 2011. Description and analysis of on-board systems of the Tu-154M No 101. Annexure Nr 2 to Final Report [13], Warsaw, (In Polish).
- [15] Committee for Investigation of National Aviation Accidents KBWL. 2011. Flight technology and its utilization. Annexure Nr 4 to Final Report [13], Warsaw, (In Polish).
- [16] Committee for Investigation of National Aviation Accidents KBWL. 2011. Description of damage to aircraft. Annexure Nr 5 to Final Report [13], Warsaw, (In Polish).
- [17] Czachor, M. 2012. Crash tests on Douglas DC-7 and Lockheed Constellation versus Tu-154M Smoleńsk crash, Smolensk Conference, Warsaw.
- [18] Ellis, G. 1984. Air crash investigation of general aviation aircraft, Capstan Publications, Greybull, WY, 1984.
- [19] Gaiderov, S.S. 2000. Electrical equipment of aircraft Tu-154B(M). Rilsk Aviation College of Technology, Rilsk. (In Russian)
- [20] Gieras, J.F. 2012. Evaluation, investigation techniques and possibility of malfunction of electric system of Tu-154M, Smolensk Conference, Warsaw.
- [21] Gieras, J.F. 2012. Hypothesis of explosion in the left wing outer fuel tank of Tu-154M due to electrical ignition of fuel-air mixture, Smolensk Conference, Warsaw.

- [22] Gieras, J.F. 2012. Full-scale crash dynamic tests of DC-7 and LC-1649 versus hypothetical collision of Tu-154M with birch tree, Smolensk Conference, Warsaw.
- [23] Gieras, J.F. 2008. Advancements in electrical machines, Springer, London-Dordrecht-Boston.
- [24] Hallquist, J.O. 2006. LS-DYNA theory manual, Livermore Software Technology Corporation, Livermore, CA.
- [25] Hemighaus, G., Boval, T., Bacha, J., Barnes, F., Franklin, M., Gibbs, L., Hogue, N., Jones, J., Lesnini, D., Lind, J., Morris, J. 2006. Chevron Aviation Fuels Technical Review (FTR-6). Chevron Corporation, p 24. <http://www.cgabusinessdesk.com>
- [26] Hibbeler, R.C. 1993. Statics and mechanics of materials, Prentice Hall, Englewood Cliffs, NJ.
- [27] Hill, R., W.J. Hughes (Editors). 1998. A review of flammability hazard of Jet A fuel vapor in civil transport aircraft fuel tanks. Report DOT/FAA/AR-98/26, US Dept of Transp., Springfield, VA.
- [28] Hummel, F., Krohn, P., Ferguson, B., Ardila, R. 2010. TAWS data extraction for NTSB identification: ENG10SA025 original, Universal Avionics Systems Corporation, Redmond, WA.
- [29] Interstate Aviation Committee (MAK). 2011. Final Report on the investigation of air accident of Tu154M registration number 101 of the Republic of Poland. Moscow. www.mak.ru/english/english.html
- [30] Interstate Aviation Committee (MAK). 2011a. Final Report on results of investigation of aviation accident involving the Tu-154B-2, tail number RA-85588, airport Surgut, on January 1, 2011. (In Russian)
- [31] Kommissarov, D. 2007. Tupolev Tu-154. The USSR's medium-range jet airliner. Aeropax, - Ian Allan Publishing, Hersham, UK.
- [32] Kosvic, T.C., L.B., Zung, M. Gersten. 1971. Analysis of fuel tank fire and explosion hazards. Technical Report AFAPL-TR-71-7. Air Force Propulsion Laboratory, WPAFB, Ohio.
- [33] Leonard, J.T. 1981. Generation of electrostatic charge in fuel handling systems: a literature survey. NRL Report Nr 8484, Naval Research Laboratory, Washington DC.
- [34] Lilley, S. 2011. System failure case studies in the sky. NASA, Safety Center, January 2011, <http://pmba.nasa.gov>
- [35] Moir, I., A. Seabridge. 2008. Aircraft systems: mechanical, electrical and avionics subsystems integration. 3rd ed. J. Wiley & Sons, Chichester, UK.
- [36] NASA Safety Center. 2011. System failure case studies – fire in the sky. <http://pmba.nasa.gov>
- [37] Nestor, L.J. 1967. Investigation of turbine fuel flammability within aircraft fuel tanks. Naval Air Propulsion Center, Philadelphia, PA, Raport No DS-67-7.
- [38] Nowaczyk K. 2011. Are the IAC (MAK) and CIAA (KBWL) raports creadible? (in Polish), Power point presentation http://smolenskrash.com/smol_conf/dane/NowaczykWizualizacja-2.pdf
- [39] Nowaczyk, K. 2012. Analysis of records of TAWS and FMS (Universal Avionics System Corporation) installed in Polish governmental aircraft Tu-154M No. 101 (in Polish) Smolensk Conference, Warsaw.
- [40] Reed, W.H., S.H. Robertson, L.W.T. Weinberg, L.H. Tyndall. 1965. Full-scale dynamic crash test of a Douglas DC-7 aircraft. Technical report FAA-ADS-37, Aviation Safety Engineering and Research, Phoenix, AZ.
- [41] Reed, W.H., S.H. Robertson, L.W.T. Weinberg, L.H. Tyndall. 1965. Full-scale dynamic crash test of a Lockheed Constellation model 1649 aircraft. Technical report FAA-ADS-38, Aviation Safety Engineering and Research, Phoenix, AZ.
- [42] Shepard, J.E., J.C. Krok, J.J. Lee. 1977. Jet A explosion experiments: laboratory testing. California Institute of Technology, Pasadena, CA.
- [43] Slensky, G. 2010. Aircraft wiring system integrity initiatives. AFRL, WPAFB, Dayton, OH, <http://wire.nasa.gov>
- [44] Soshin, V.M. (Editor). 2005. Aircraft Tu-154M, book 2, ed. Samara State Aerospace University, Samara.
- [45] Szuladzinski, G. 2012. Some mechanical and structural aspects of the Smolensk air crash. Raport No 456, Version 6, Analytical Service Pty Ltd, Northbridge, Australia.
- [46] The lucky Tu-154, English Russia, November 4, 2011, <http://goryachev.livejournal.com/38422.html>

- [47] Tomlinson, S. 2012. Watch the incredible moment a passenger jet is crashed MailOnline, April 30, 2012, article No 2137327, <http://www.dailymail.co.uk>
- [48] Tu-154. Catalogue of parts and compilation of units. Chapter 27: Control, in Russian, AviaMedia, 1984, updated 2003.
- [49] Tu-154B. User's and technical service manual, in Russian, Book 7, Part 1. Electric equipment, in Russian, Aviakor, Samara, 1994.
- [50] Tu-154M. User's technical guidance, Chpt. 28. Fuel system.
- [51] Update on investigation of airliner tank explosion in India, NTSB, July 12, 2006, <http://www.nts.gov/news/2006/060712a.htm>
- [52] Wing of Tu-154 aircraft, in Russian, Virtual cabinet of aircraft construction, http://cnit.ssau.ru/virt_lab/kriilo/index.htm
- [53] Wood R.H., Sweginnis, R.W. 2006. Aircraft accident investigation, 2nd ed., Endeavor Books, Casper, WY.
- [54] Znichenko, V.I. 1998. Construction and user manual of Tu-154M aircraft, Federal Air Transport Service of Russia, NLMK, Academy of Civil Aviation, Sankt Petersburg.

WYBRANE ASPEKTY TECHNICZNE KATASTROFY SAMOLOTU TU-154M W SMOLENSKU W DNIU 10 KWIETNIA 2010

STRESZCZENIE

Przedstawiona tutaj praca składa się z trzech części. Część I zatytułowana "Ocena, technika badań oraz mo-

żliwość awarii systemu elektroenergetycznego samolotu Tu-154M" omawia system elektroenergetyczny Tu154M. Po krótkim wprowadzeniu do systemów elektroenergetycznych samolotów, przedstawiono wyniki projektowania odwrotnego oraz analizy generatora synchronicznego GT40PCh6 o wzbudzeniu elektromagnetycznym z uwzględnieniem przebiegów prądów podczas zwarcia.

Przykładem awarii generatora GT40PCh6 jest pożar Tu-154B-2 w dniu 1 stycznia 2011 przed startem na lotnisku w Surgucie (lot 7K348). Podano wytyczne do badań wyposażenia elektrycznego oraz instalacji elektrycznej samolotów po katastrofie. Brak jest dowodów na przeprowadzenie prawidłowych badań większości wyposażenia elektrycznego Tu-154M nr 101 po katastrofie w dniu 10 kwietnia 2010. Obecnie jest bardzo trudno stwierdzić, czy nastąpiła awaria systemu elektroenergetycznego Tu-154M Nr 101 w ostatnich sekundach lotu, czy też nie.

W części II zatytułowanej "Hipoteza eksplozji w zewnętrznym zbiorniku paliwa lewego skrzydła na skutek zapłonu elektrycznego mieszanki paliwo-powietrze" przedstawiono analizę układu paliwowego oraz możliwości wybuchu mieszanki paliwo-powietrze na skutek luku elektrycznego lub ładunków statycznych w samolocie Tu-154M Nr 101. Do wybuchów zbiorników paliwa doszło podczas lotu Boeinga 747-131 TWA 800 17 czerwca, 1996 oraz podczas postoju Boeinga 727-200 na lotnisku w Bangalore 4 maja 2006. Choć prawdopodobieństwo wybuchu paliwa w zbiorniku zewnętrznym lewego skrzydła na skutek zwarcia instalacji, luku elektrycznego czy też ładunków statycznych jest niskie, problem ten powinien być dokładnie rozważony podczas przyszłych badań wraku oraz dostępnych urządzeń i przewodów elektrycznych.

Część III zatytułowana "Porównanie testów dynamicznych zderzeń w pełnej skali z przeszkodami przy użyciu samolotów DC-7 oraz LC-1649 z hipotetyczną kolizją Tu-154M z brzoza" dyskutuje analizę porównawczą hipotetycznej kolizji Tu-154M z brzoza oraz testami dynamicznymi zderzeń z przeszkodami terenowymi przy użyciu samolotów DC-7 oraz LC-1649. Analiza porównawcza dotyczy danych technicznych samolotów, różnic w ich konstrukcji oraz warunków przeprowadzenia zderzeń.